

INCH-POUND

MIL-PRF-32432(GL)

9 January 2013

## PERFORMANCE SPECIFICATION

### MILITARY COMBAT EYE PROTECTION (MCEP) SYSTEM

This specification is approved for use by all Departments and Agencies of the Department of Defense.

#### 1. SCOPE

1.1 Scope. This specification covers Military Combat Eye Protection (MCEP) system. This document covers both prescription and non-prescription wearers.

1.2 Classification. The eyewear will be of the following Classes as specified.

##### 1.2.1 Classes.

- Class 1 Spectacles
- Class 1a Spectacles compatible with Universal Prescription Lens Carrier (UPLC)
- Class 2 Goggles
- Class 2a Goggles compatible with UPLC
- Class 3 Hybrid Goggle Design
- Class 3a Hybrid Goggle Design compatible with UPLC

#### 2. APPLICABLE DOCUMENTS

2.1 General. The documents listed in this section are specified in Sections 3, 4 or 5 of this specification. This section does not include documents cited in other sections of this specification or recommended for additional information or as examples. While every effort has been made to ensure the completeness of this list, document users are cautioned that they must meet all specified requirements of documents cited in Sections 3, 4 or 5 of this specification whether or not they are listed.

Comments, suggestions, or questions on this document should be addressed to: Attn: DLA Troop Support Standardization Team, 700 Robbins Avenue, Philadelphia, PA 19111-5096. Since contact information can change, you may want to verify the currency of the address information using Acquisition Streamlining and Standardization Information System (ASSIST) online database at <https://assist.dla.mil>.

## MIL-PRF-32432(GL)

### 2.2 Government documents.

2.2.1 Specifications, standards, and handbooks. The following specifications, standards, and handbooks form a part of this document to the extent specified herein. Unless otherwise specified, the issues of these documents are those cited in the solicitation or contract.

#### FEDERAL STANDARDS

FED-STD-595C - Colors Used in Government Procurement

Black 357 - see color chip 27041

Tan 499 - see color chip 20180

Foliage Green 504 - see color chip 24165

#### DEPARTMENT OF DEFENSE SPECIFICATIONS

MIL-DTL-83133 - Turbine Fuel, Aviation, Kerosene Type, JP-8

MIL-PRF-6083 - Hydraulic Fluid, Petroleum Base for Preservation and Operation

MIL-PRF-46170 - Hydraulic Fluid, Rust Inhibited, Fire Resistant, Synthetic Hydrocarbon Base

(Copies of these documents are available online at <https://assist.dla.mil/quicksearch/> or from the Standardization Document Order Desk, 700 Robbins Avenue, Building 4D, Philadelphia, PA 19111-5094.)

2.2.2 Other Government documents, drawings, and publications. The following other Government documents, drawings, and publications form a part of this document to the extent specified herein. Unless otherwise specified, the issues are those cited in the solicitation or contract.

#### DRAWINGS

##### U.S. ARMY RESEARCH, DEVELOPMENT, AND ENGINEERING COMMAND

Drawing 5-0005-0001 Universal Prescription Lens Carrier

ITOP 4-2-805 - Projectile Velocity and Time of Flight Measurements

(Application for copies should be addressed to the Defense Technical Information Center, 8725 John J. Kingman Road, Ste. 0944, Fort Belvoir, VA 22060-6218.)

(Copies of documents required by contractors in connection with specific acquisition functions should be obtained from the contracting activity or as directed by the contracting activity.)

MIL-PRF-32432(GL)

2.3 Non-Government publications. The following documents form a part of this document to the extent specified herein. Unless otherwise specified, the issues of these documents are those cited in the solicitation or contract.

AMERICAN ASSOCIATION OF TEXTILE CHEMISTS AND COLORISTS (AATCC)

AATCC Evaluation Procedure 9, Visual Assessment of Color Difference of Textiles

(Copies are available on line at <http://www.aatcc.org> or from the American Association of Textile Chemists and Colorists, P.O. Box 12215, Research Triangle Park, NC 27709-2215.)

AMERICAN NATIONAL STANDARDS INSTITUTE (ANSI)

- ANSI S12.42 - Methods for the Measurement of Insertion Loss of Hearing Protection Devices in Continuous or Impulsive Noise Using Microphone-in-Real-Ear or Acoustic Test Fixture Procedures
- ANSI-Z80.30 - Ophthalmics – Toric Intraocular Lenses
- ANSI-Z87.1-2003 - American National Standard for Occupational and Educational Personal Eye and Face Protection Devices
- ANSI/ISEA-Z87.1-2010 – American National Standard for Occupational and Educational Personal Eye and Face Protection Devices

(Copies are available online at <http://webstore.ansi.org/ansidocstore> or from American National Standards Institute, 25 West 43rd Street, 4th floor, New York, NY 10036.)

AMERICAN SOCIETY FOR QUALITY (ASQ)

ANSI/ASQ Z1.4 – Sampling Procedures and Tables for Inspection of Attributes

(Copies are available online at <http://www.asq.org> or from the American Society for Quality, 600 North Plankinton Avenue, Milwaukee, WI 53203.)

ASTM INTERNATIONAL

- ASTM D1003 - Standard Test Method for Haze and Luminous Transmittance of Transparent Plastics
- ASTM D3359 - Standard Test Methods for Measuring Adhesion by Tape Test
- ASTM D6413 - Standard Flame Resistance of Textiles (Vertical Test)
- ASTM G155- Standard Practice for Operation of Xenon Arc Light Apparatus for Exposure of Non-Metallic Materials

(Copies of documents are available online at <http://www.astm.org> or from the ASTM INTERNATIONAL, 100 Barr Harbor Drive, P.O. Box 700C, West Conshohocken, PA 19428-2959.)

## MIL-PRF-32432(GL)

## OTHER PUBLICATIONS

Repeat Insult Patch Test – Modified Draize Procedure  
Principles and Methods of Toxicology (Fourth Edition), A. Wallace Hayes (Editor),  
pp. 1057-1060, 2001.

(Copies are available online at <http://www.taylorandfrancis.co.uk/> or from Taylor and Francis, 325 Chestnut Street, Philadelphia, PA 19106.)

2.4 Order of precedence. Unless otherwise noted herein or in the contract, in the event of a conflict between the text of this document and the references cited herein, the text of this document takes precedence. Nothing in this document, however, supersedes applicable laws and regulations unless a specific exemption has been obtained.

### 3. REQUIREMENTS

3.1 Specification sheets. The individual item requirements shall be as specified herein and in accordance with the applicable specification sheet. In the event of any conflict between the requirements of this specification and the specification sheet, the latter shall govern.

NOTE: All requirements pertain to Class 1, Class 1a, Class 2, Class 2a, Class 3 and Class 3a MCEP systems unless otherwise specified.

3.2 Qualification. Eyewear furnished under this specification shall be products that are authorized by the qualifying activity for listing on the applicable qualified products list before contract award (see 4.1.1 and 6.3). A process in advance of and independent of an acquisition by which a manufacturer's capabilities, or a manufacturer's or distributor's products are examined, tested, and approved to be in conformance with specification requirements, and subsequent approval for or listing of products on a qualified products list (QPL) or manufacturers on a qualified manufacturers list (QML) (see 4.1.1.2 and 6.3).

3.3 First article. When specified (see 6.2), a sample shall be subjected to first article inspection (see 6.3.1) in accordance with 4.2.

3.4 Recycled, recovered, or environmentally preferable materials. Recycled, recovered, or environmentally preferable materials should be used to the maximum extent possible, provided that the material meets or exceeds the operational and maintenance requirements, and promotes economically advantageous life cycle costs.

#### 3.5 System configuration.

3.5.1 General. The MCEP system shall consist of a system containing: eyewear (Class 1 spectacles, Class 1a spectacles with capability to be compatible with the UPLC, Class 2 goggles, Class 2a goggles with capability to be compatible with the UPLC, Class 3 hybrid goggle, or Class 3a goggles with capability to be compatible with the UPLC), spare lens (with nose piece, if applicable) and carrying case, instruction booklet, cleaning

## MIL-PRF-32432(GL)

cloth, anti-fog reapplication and a retaining strap. Lenses shall be capable of being easily removed from the primary frame and replaced with another lens. For those products designed without a frame around the lens, the lens shall be easily removed from the supporting structure (i.e., temple arms and/or retention strap) and replaced with another lens. Goggles shall also include a protective sleeve. Classes 1a, 2a and 3a shall include any adaptors required to interface with the UPLC system.

a. Class 1 spectacles. Class 1 spectacles are defined as eyewear that protects the wearer's eyes from hazards/threats associated with fragmentation and light energy; additional wind/dust protection in the form of a seal around the eye socket or spectacle/frame perimeter is optional. If a removable wind/dust protective seal is proposed as part of the configuration, it shall be included as part of the kit, and the kit shall meet all specification requirements both with and without the removable seal in place. Primary means of retention for spectacles shall be temple arms or retention strap (for those designs that do not have temple arms); an additional retention strap shall be included with the system for use in conjunction with, or in place of, the temple arms for designs that include temple arms.

b. Class 1a spectacles. Class 1a spectacles are defined as eyewear that protects the wearer's eyes from hazards/threats associated with fragmentation and light energy and is compatible with the UPLC. Additional wind/dust protection in the form of a seal around the eye socket is optional. Primary means of retention for spectacles shall be temple arms or retention strap (for those designs that do not have temple arms); an additional retention strap shall be included with the system for use in conjunction with, or in place of, the temple arms for designs that include temple arms.

c. Class 2 goggles. Class 2 goggles are defined as eyewear that protects the wearer's eyes from hazards/threats associated with fragmentation and light energy, as well as from wind and dust, providing a protective seal around the eyes. The primary means of retention for goggles shall be a goggle strap. A protective sleeve shall be provided for the goggle when not in use (such as when stowed on helmet). If a removable facefoam is proposed as part of the configuration, it shall be included as part of the kit; the kit shall meet all specification requirements both with and without the removable facefoam.

d. Class 2a goggles. Class 2a goggles are defined as eyewear that protects the wearer's eyes from hazards/threats associated with fragmentation and light energy, as well as from wind and dust, providing a protective seal around the eyes and is compatible with the UPLC. The primary means of retention for goggles shall be a goggle strap. A protective sleeve shall be provided for the goggle when not in use (such as when stowed on helmet).

e. Class 3 hybrid goggles. Class 3 hybrid goggles are defined as eyewear that provides the same protection as the goggle, with the exception that it cannot take a 3<sup>rd</sup> (center) impact during ballistic fragmentation testing due to the physical nature of the design (i.e., either a goggle design with individual right and left lenses or a goggle design

## MIL-PRF-32432(GL)

with a lens height of less than five times the diameter of the projectile (2.73 cm) for the center section of the lens).

f. Class 3a hybrid goggles. Class 3a hybrid goggles are defined as eyewear that provides the same protection as the goggle, with the exception that it cannot take a 3<sup>rd</sup> (center) impact during ballistic fragmentation testing due to the physical nature of the design (i.e., either a goggle design with individual right and left lenses or a goggle design with a lens height of less than five times the diameter of the projectile (2.73 cm) for the center section of the lens) and is compatible with the UPLC.

Note: It is possible that some eyewear may be capable of being configured as, and qualified as, more than one Class of MCEP system provided all requirements for each respective Class of MCEP system are met.

3.5.1.1 Eyewear. Eyewear shall provide protection to the eye against ballistic (fragmentation) threats, as well as from electromagnetic radiation, to include bright sunlight and harmful ultraviolet (UV) radiation. Ballistic fragmentation protection and UV protection is required in all possible configurations. At least one configuration shall protect the eye from bright sunlight (i.e., sunglasses). Class 1a, 2a and 3a shall have a means of holding the UPLC.

NOTE: Here, a lens is defined as an optical quality protective shield for the eye(s). Configuration is defined as a lens, or combination of lenses, arranged together to achieve the desired protection and prescription. No more than two (2) types of lenses (or four exposed surfaces), including prescription lenses, shall be arranged in front of the eyes in any configuration. A self-contained lens system (i.e., a thermal lens with a sealed space between two lenses, an electrochromic lens configuration, etc.) shall be counted as two surfaces (front and back). Those surfaces that are physically sealed in between shall not be counted.

3.5.1.1.1 Color. Class 1 and Class 1a frames shall be available in Black 357. Class 2, Class 2a, Class 3 and Class 3a frames shall be available in Black 357, Tan 499 and Foliage Green 504. The finished eyewear shall match the standard sample for shade and appearance, and shall, unless otherwise indicated, be equal to or better than the standard sample with respect to all characteristics for which the sample is referenced (see FED-STD-595C). Retention straps and protective sleeves shall match the eyewear frame in solid color and/or corresponding US military camouflage pattern, and shall match the corresponding standard for shade and appearance. Carrying cases shall match the eyewear frame in solid color and/or corresponding US military camouflage pattern. Findings (thread, zippers, webbing, snaphooks, etc.) shall be a reasonable match to the carrying case. Matte finishes are preferred. (see 6.2).

3.5.1.2 Carrying case. A carrying case shall be provided for each class of eyewear. Separately sized/designed carrying cases may be used for each class as necessary. The carrying case shall be capable of carrying one MCEP system (eyewear, retaining strap, instruction booklet, cleaning cloth and anti-fog reapplication) with or without attached

## MIL-PRF-32432(GL)

prescription lenses and at least one extra protective lens. The carrying case shall provide a means of drainage. The carrying case shall easily attach/detach to/from the soldier's equipment belt and load bearing equipment. The method for attaching/detaching the case to/from the user's belt, vest or packs shall be easy to accomplish, yet durable and remain attached during field operations such as crawling, climbing, etc. The carrying case shall be designed so as to allow for quick and easy access to the MCEP system by the user and shall be operable and resistant to breaks and cracks, discoloration, corrosion, and rust during operation, shipping, and storage.

3.5.1.3 Instruction booklet. An instruction booklet shall be provided, which, at a minimum, includes a description and use of the MCEP system to include lens installation and removal, configurations, maintenance and cleaning procedures. If the item is UPLC compatible, the instruction booklet shall also include applicable universal prescription lens carrier (UPLC) insertion/removal instructions and diagrams. Information related to safety shall also be included, as appropriate, and shall be made to stand out from the remainder of the text. Language shall be simple, clear and concise. Type style, size and spacing shall be in accordance with best commercial practices for technical publications. The instruction booklet shall be small enough to enable packing in the MCEP system carrying case with the components as specified in 3.5.1.2, yet the print shall be large enough to be read by the individual.

3.5.1.4 System retention. Class 1, Class 1a, Class 2, Class 2a, Class 3 and Class 3a MCEP systems shall provide maximum system retention during conduct of rigorous activities in all configurations. Class 1 and Class 1a primary means of retention for spectacles shall be temple arms or retention strap (for those designs that do not have temple arms); an additional retention strap shall be included with the system for optional use in conjunction with, or in place of, the temple arms for designs that include temple arms. Class 2 and Class 2a primary means of retention shall be a goggle strap. Class 3 and Class 3a primary means of retention shall be a goggle strap. Retention of the Class 2, Class 2a, Class 3 and Class 3a shall be such that the items may be worn on the helmet when not in use.

3.5.1.5 Component changes. Component changes such as installation/removal of protective lenses, retention straps, nose pieces, frames and UPLC compatibility shall not require the use of tools, and shall be able to be accomplished during day and night conditions while wearing the various clothing and equipment specified in section 3.5.1.

3.5.1.6 Uniformity in system dimensions. The MCEP system end item components (i.e. lenses, frames, nose pieces, prescription lens carrier adaptors (as applicable), straps and associated attachment mechanisms) shall be uniform in dimension between items of the same class, size and product. The lenses, frames, nose pieces, prescription lens carrier adaptors (as applicable), straps and attachment mechanisms shall be able to be changed out from one item of the same product line and used on another item of the same product line with no degradation of capabilities.

## MIL-PRF-32432(GL)

3.5.2 System weight. The weight of the Class 1 and Class 1a MCEP eyewear shall not exceed 45.2 grams (1.6 ounces) for any eyewear configuration proposed as part of the system, to include any removable eyewear components, such as removable facefoam and retention straps, installed on the eyewear. The weight of the empty carrying case for Class 1 and Class 1a shall not exceed 141.75 grams (5 ounces) for any eyewear configuration proposed as part of the system, to include any removable eyewear components, such as removable face foam and retention straps, installed on the eyewear. The weight of the Class 2, Class 2a, Class 3 and Class 3a MCEP eyewear shall not exceed 144.58 grams (5.1 ounces). The weight of the empty carrying case for Class 2, Class 2a, Class 3 and Class 3a shall not exceed 226.80 grams (8 ounces).

3.5.3 System interface requirements: The MCEP system shall functionally and comfortably integrate when being used with current weapons, clothing, and equipment normally carried, worn, or used, with the exception of Nuclear, Biological and Chemical (NBC) protective masks.

3.5.3.1 Advanced Combat Helmet (ACH) or Enhanced Combat Helmet (ECH). Class 1, Class 1a, Class 2, Class 2a, Class 3 and Class 3a MCEP systems shall be capable of being worn with the ACH or ECH. Class 2, Class 2a, Class 3 and Class 3a shall be capable of being worn over or under the ACH or ECH.

3.5.3.2 Army Combat Vehicle Crewman (CVC) helmet (DH-132B) and the Marine Corps Advanced CVC helmet. Class 2, Class 2a, Class 3 and Class 3a MCEP systems shall be capable of being worn with the CVC helmet (DH-132B) and the Marine Corps Advanced CVC helmet. Class 2, Class 2a, Class 3 and 3a shall not break the ear cup seal when worn over the helmet. Class 1 and 1a spectacles claiming compatibility with this helmet shall demonstrate they can do so without degrading the noise attenuation characteristics of the CVC ear cups by more than 5 decibels.

3.5.3.3 Lightweight helmet (LWH). Class 1, Class 1a, Class 2, Class 2a, Class 3 and Class 3a MCEP systems shall be capable of being worn with the Marine Corps LWH. Class 2, Class 2a, Class 3 and Class 3a shall be capable of being worn over the LWH.

3.5.3.4 Weapons. Class 1, Class 1a, Class 2, Class 2a, Class 3 and Class 3a MCEP systems with and without the UPLC containing prescription lenses (as applicable) of the testable ranges as outlined in 3.5.3.7 shall not degrade the soldiers' ability to shoulder, aim, fire at and hit targets, carry, or inhibit head flexing/rotation when using the following:

M-16 RIFLE family, M-4 CARBINE "FLAT TOP", M-24 with Leupold sight, M203, M-249, M-60, M-67 mortar sight, M-240B, Light Anti-Tank Weapon (LAW), TOW missile ITAS, DRAGON, SAW, M18A1 CLAYMORE, M141 BUNKER DEFEAT MUNITION, M136E1 AT4CS, FAMILY OF SMOKE GRENADES, HAND GRENADES, PYROTECHNICS AND SIMULATORS, M136 AT4, M72 LAW (LIGHTWEIGHT ANTI-ARMOR SERIES), M-203 GL, IRON SIGHT M-240B MG, IRON SIGHT M60 MG, IRON SIGHT M-24 SWS, M107 LRSR, M110 SAAS, M500 SHOTGUN, M26 SHOTGUN, M320 GL.M



## MIL-PRF-32432(GL)

3.5.3.5 Optics/displays: Class 1, Class 1a, Class 2, Class 2a, Class 3 and Class 3a MCEP systems with and without the UPLC containing prescription lenses (as applicable) of the testable ranges as outlined in 3.5.3.7 shall be capable of being used physically and optically with the following without degrading the user's ability: TOW missile ITAS, M-144 telescope (spotting scope), JAVELIN command launch unit, M-67 mortar sight, AN/PVS-4, AN/PVS-6, AN/PVS-10, AN/PVS-14 (monocular image intensifier), AN/PAS 13 (thermal weapon sight), AN/TVS 5 (monocular image intensifier), M-68 close combat optic, M-24 and M22 binoculars, XM25 Stabilized Binocular, AT4, RS, M126 Bunker Defeat Munitions, M68 CCO, M150 RCO, A2 IRON SIGHT, BACK UP IRON SIGHT (BUIS), M145 MGO, LEUPOLD FIXED 10X, LEUPOLD 4.5-14X, LEUPOLD 3.5 -10X, REDFIELD BUIS, M151 SPOTTING SCOPE, PVS14, PVS-7 Image Intensifier, AN/PSQ-20 ENVGS (Enhanced Night Vision Goggles).

3.5.3.6 Environmental protective clothing. The MCEP system shall be capable of being worn with the 3<sup>rd</sup> Gen Extreme Cold Weather Clothing System (ECWCS).

3.5.3.7 Prescription lens. Class 1a, Class 2a and Class 3a MCEP systems shall be able to accommodate the use of the UPLC filled with military polycarbonate prescription lenses (from -10 to +8 diopters sphere with up to -3.25 diopters of cylinder) without degrading the system performance beyond requirement limits.

3.6 Materials/characteristics. Use of recycled, recovered, or environmentally preferable materials is encouraged when practical, provided the performance requirements are met. Unless otherwise noted, both clear and sunglass lenses shall be included as part of all testing.

3.6.1 Mildew resistance. The textile materials used in the eyewear shall be resistant to mildew for a service life of 6 months or greater and a shelf life of 5 years or greater.

3.6.2 Chemical resistance. The eyewear lenses shall maximize resistance to:

6.0% Sodium Hypochlorite by weight; insect repellent-controlled release diethyl toluamide (30% concentration DEET), Fire resistant hydraulic fluid (MIL-PRF-46170), Hydraulic Fluid, Petroleum Base (MIL-PRF-6083), Gasoline (87% Octane), Motor oil (Quaker State Peak Performance (SAE 10W-30), and JP8 fuel (MIL-DTL-83133E) without degrading performance beyond requirement limits.

3.6.3 Ballistic fragmentation characteristics. The eyewear shall provide ballistic fragmentation protection in all configurations.

3.6.3.1 Ballistic fragmentation protection, Class 1 and Class 1a spectacles. The spectacles shall provide ballistic fragmentation protection in all configurations. Spectacles shall be sufficiently durable to remain intact (i.e., all components required for protection and proper retention of the eyewear remain attached) upon/after impact. Class

## MIL-PRF-32432(GL)

1a spectacles shall be tested both with and without prescription lenses for initial approval of the design for use with the UPLC.

3.6.3.2 Ballistic fragmentation protection, Class 2, Class 2a, Class 3 and Class 3a goggles. The goggles shall provide ballistic fragmentation protection in all configurations. Goggles shall be sufficiently durable to remain intact (I.e., all components required for protection and proper retention of the eyewear remain attached) upon/after impact. Class 2a and Class 3a goggles shall be tested both with and without prescription lenses in the appropriate configuration for initial approval of the design for use with the UPLC.

3.6.3.3 Universal Prescription Lens Carrier (UPLC) adaptors. Class 1a, Class 2a and Class 3a adaptors that are used to make the system compatible with the UPLC, shall be able to survive a ballistics fragmentation impact in all configurations for which they are intended. The assembly and associated interfaces shall be sufficiently durable to remain intact upon impact.

3.6.4 Optical characteristics. All classes of eyewear shall be capable of meeting the optical requirements in all configurations. Class 1a, Class 2a and Class 3a shall be capable of meeting the optical requirements with and without the UPLC installed (to include the use of multiple nosepieces to accommodate both prescription and non-prescription wearers). Optical tests with the UPLC installed shall be conducted without prescription lenses in place. All eyewear shall be able to pass all optical requirements at all points within the critical optical area.

3.6.4.1 Luminous transmittance/neutrality/chromaticity.

3.6.4.1.1 Multiple lenses. If, for each Class of MCEP system, multiple lenses are used to provide ballistic fragmentation and sun/UV protection, the luminous transmittance shall be as follows:

3.6.4.1.1.1 Configuration providing ballistic fragmentation protection clear lens only. The photopic luminous transmittance (for the light adapted eye) of the lens shall NOT be less than 89 percent. The scotopic luminous transmittance of the lens shall not be less than 85%.

3.6.4.1.1.2 Configuration providing ballistic fragmentation protection and bright sunlight (sunglass) protection. The photopic luminous transmittance of the configuration shall be within 12 to 18 percent when measured within the critical optical areas.

3.6.4.1.1.3 Variable transmission lenses. Lenses that transition from clear to dark states and vice-versa shall meet the above transmittance requirements for the corresponding state (clear or dark). Lenses shall be capable of transitioning from state to state in 3 seconds or less.

## MIL-PRF-32432(GL)

3.6.4.1.2 Neutrality. The spectral transmittance of the sunglass lens may vary with wave lengths between 430 and 730 nanometers (nm); the average percentage deviation within nine spectral bands shall be less than 12 percent. The spectral distribution curve shall show a reasonably even distribution throughout the visible spectrum to insure that color distortion will not be excessive.

3.6.4.1.3. Chromaticity. The chromaticity coordinates x and y of the lenses shall be within the limits indicated in Figure 1.

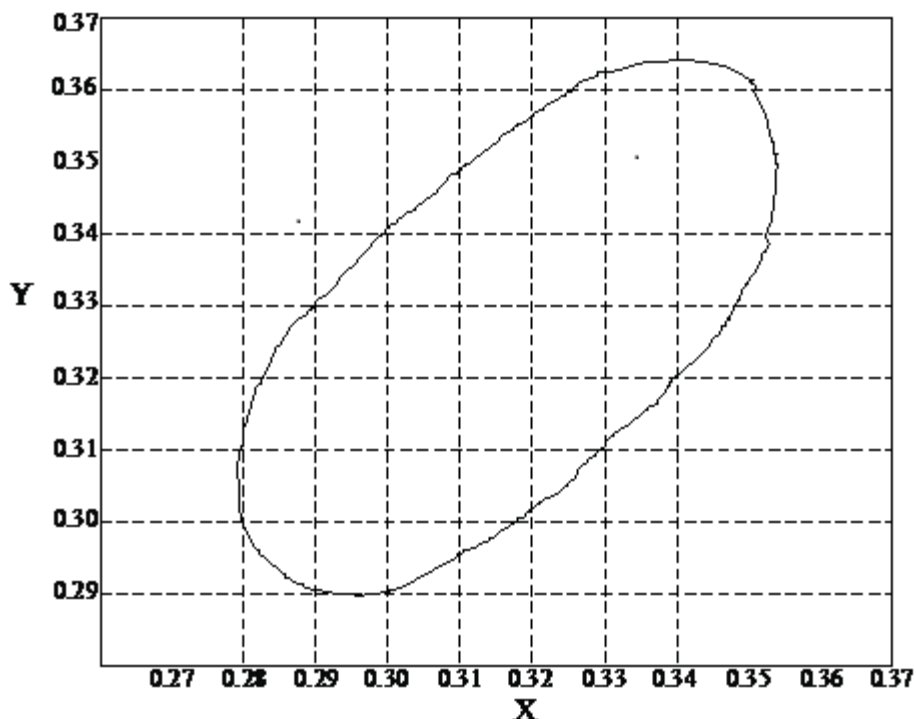

FIGURE 1. Chromaticity coordinates

3.6.4.2 Field of view. The MCEP system shall provide unobscured vision with a field of view adequate for mission with and without the UPLC installed.

3.6.4.3 Resistance to temporary or permanent optical degradation. Class 1, Class 1a, Class 2, Class 2a, Class 3 and Class 3a systems shall maximize the resistance to scratching abrasion, and fogging so as to minimize interference with vision.

3.6.4.3.1 Haze/resistance to scratching/abrasion. Initial haze of the eyewear for all MCEP lenses shall be no greater than 3%. No more than six percent (6%) haze shall be added to the baseline haze value as a result of abrasion testing.

3.6.4.3.2. Resistance to fogging. The item shall not fog to the extent that the user is unable to perform their intended mission. A topical antifog treatment compatible with the eyewear coatings shall be included as part of the MCEP kit.

## MIL-PRF-32432(GL)

3.6.4.4 Prismatic power. Prismatic Power requirements for the eyewear shall be in accordance with ANSI Z87.1.

3.6.4.5 Optical distortion. The eyewear lens(es) shall be free of blurs or distortion (evidenced by waves or ripples or shearing patterns) in the image of a straight line in any meridian when viewed through the lens. Conformance shall be determined via the acceptable standards shown in Figure 2.

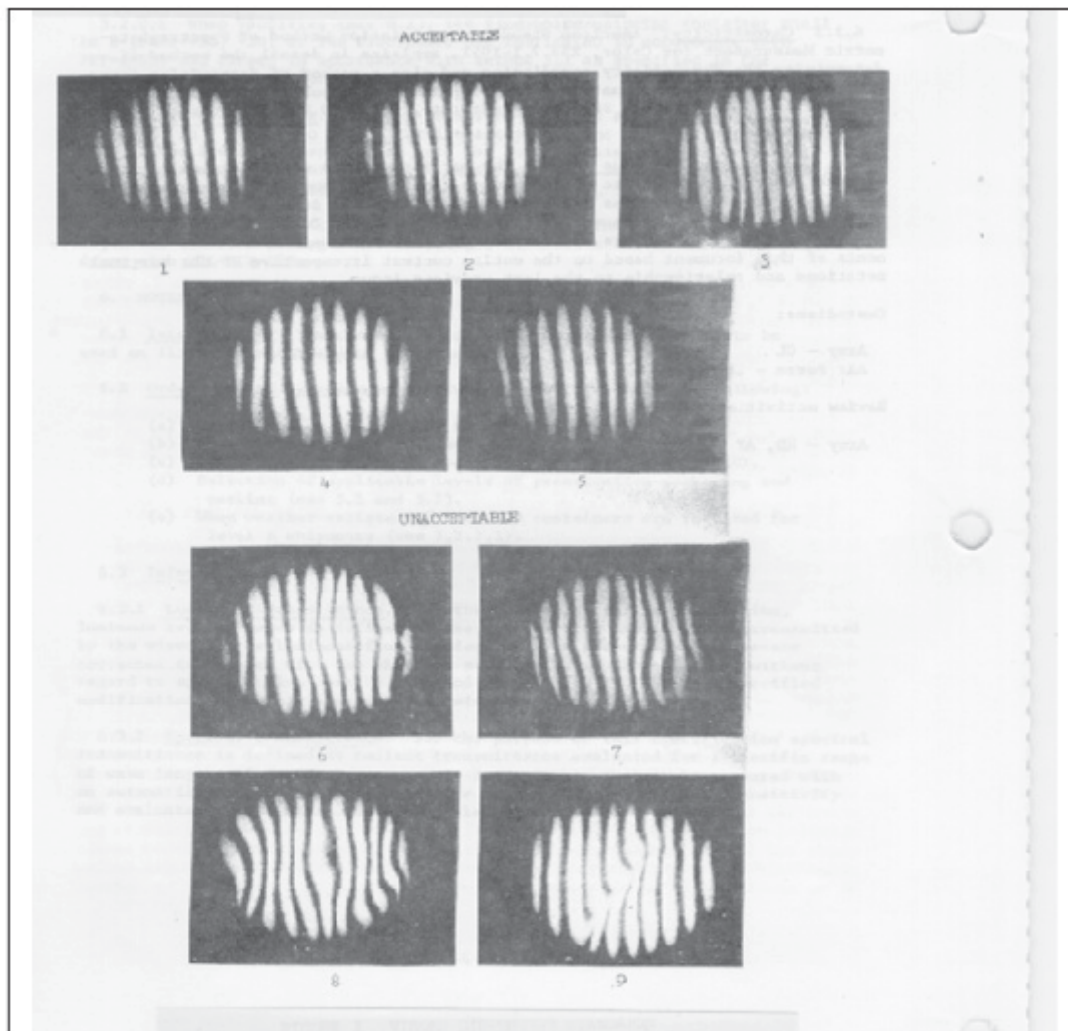

FIGURE 2. Optical distortion standards

3.6.4.6 Ultraviolet absorption. The eyewear lens(es) shall absorb at least 99.9 percent of the incident ultraviolet radiation in the range 290 to 380 nanometers (nm).

3.7 Durability.

## MIL-PRF-32432(GL)

3.7.1 Carrying case protection: The carrying case shall protect the eyewear during carrying, storage, and shipping such that there is no degradation beyond the requirement limits in optical or ballistic fragmentation performance. The carrying case shall minimize dirt infiltration and scratching of lenses.

3.7.2 Service life/shelf life. The system shall have a minimum field life of six months and a minimum shelf life of 60 months or longer.

3.7.3 Repair. The system shall be capable of being repaired by replacing components that have become damaged. Repairs shall be capable of being performed without tools.

3.7.4 Environment. The MCEP system shall be capable of being worn/used in all climatic categories (i.e. -60 °F to 120 °F) during day, dusk, and nighttime operations, and during various environmental conditions, such as rain, snow, wind, etc.

3.7.4.1 Eyewear. The eyewear shall not warp or deform, delaminate, discolor, corrode, rust, or crack, nor shall its ballistic fragmentation or optical characteristics be degraded beyond the requirement limits during operation, shipping, or storage in all climatic categories.

3.7.4.1.1 Temperature: There shall be no degradation of the eyewear (to include configurations with removable eyewear components, such as removable facefoam and retention straps) beyond the requirement limits following exposure for 72 hours at 160°F and 72 hours at -60°F.

3.7.4.1.2 Solar radiation: There shall be no degradation of the eyewear (to include configurations with removable eyewear components, such as removable facefoam and retention straps) beyond the requirement limits when tested against 200 hours of simulated solar radiation.

3.7.4.1.3 Humidity: There shall be no degradation of the eyewear beyond the requirement limits after exposure to 10 cycles for a combined total of 240 hours of temperature and humidity.

3.7.4.1.4 Adhesion. If a coating has been applied to the lens, the coating on the front surface and back surface of the lens shall not be able to be removed, dislodged, or affected in any way.

3.7.4.1.5 Wind/dust. The Class 2, Class 2a, Class 3 and Class 3a eyewear shall provide protection to the eyes from wind and dust. The design of the goggles shall minimize the wind and dust entering the space between the eyes and the goggle lens(es).

3.7.4.1.6 Salt water. There shall be no degradation beyond the requirement limits when exposed to salt water.

### 3.8 Human factors.

## MIL-PRF-32432(GL)

3.8.1 Fit adjustment.

3.8.1.1 Sizing/fit. The MCEP system shall accommodate (i.e., fit, adjust, and/or successful use) U.S. Army target audience soldiers with 5th percentile female through 95th percentile male design critical dimensions, while wearing appropriate clothing and individual equipment. Sufficient numbers of sizes for each Class of MCEP system, and adjustments within the sizes, shall be provided to correctly fit the full range of body dimensions of the target audience. When MCEP systems are worn with the UPLC, the vertex distance to the corrective lenses shall minimize eyelash contact.

3.8.1.2 Pantoscopic tilts and faceform angles. The UPLC interface for Class 1a, Class 2a and Class 3a systems shall be such that the pantoscopic tilt of the UPLC when installed in the eyewear is 15 degrees or less. Negative pantoscopic tilts are not acceptable. The UPLC interface design shall not visibly distort the faceform angle of the UPLC when the UPLC is installed (empty of prescription lenses) into the eyewear.

3.8.1.3 Adjustment. There shall be a means to adjust the eyewear for proper fit/comfort.

3.8.2 Comfort. MCEP system shall be designed to minimize localized discomfort when used alone or in conjunction with the items identified in paragraph 3.5.3. The finished parts of the MCEP system shall be free of sharp/rough edges which could result in discomfort or abrasion to the face.

3.8.3 Donning/doffing. The MCEP system shall be easily and quickly (less than 10 seconds) donned and doffed with minimal realigning and readjusting. Donning/doffing of the spectacle shall be without the retention strap since its use is optional, and shall be to/from the carrying case. Donning/doffing of the eyewear in general shall be accomplished without removing other equipment, to include the LWH, ECH, ACH and the CVC helmet, and heavy gloves (trigger finger and Arctic mittens). The MCEP system shall be easily and quickly (less than 10 seconds) accessed from the protective carrying case when attached to the soldier's belt, vest, or other equipment.

3.8.4 Use. Users of the MCEP system shall be able to accomplish the following (as a minimum) in order to make the system function (Tasks may or may not be required, based on selected configuration):

- a. Stow/remove MCEP system to/from carrier
- b. Adjust Class 1 and Class 1a MCEP system to fit on the face in the as worn configuration under the helmet (LWH, ACH, ECH, CVC (As applicable)).
- c. Adjust Class 2, Class 2a, Class 3 and Class 3a MCEP system to fit over the helmet (CVC; LWH, ACH, ECH).
- d. Adjust Class 2, Class 2a, Class 3 and Class 3a MCEP system to fit on the face in the as worn configuration under the helmet (CVC; LWH, ACH, ECH).
- e. Install/remove lenses
- f. Manipulate movable parts

MIL-PRF-32432(GL)

- g. Perform operator level Preventative Maintenance Checks and Services (PMCS)
- h. Install/remove the UPLC (Class 1a, 2a and 3a only)

3.8.5 User survivability. The MCEP system shall have no adverse impact upon user survivability. Detection of the system by reflected light is a potential survivability issue which shall be eliminated or minimized to the greatest extent possible.

3.9 Safety/health hazards

3.9.1 Risk assessment. MCEP system shall comply with all safety and health standards and performance requirements of this section. Residual user safety or health hazards (those introduced by the use of the product) shall be controlled to a hazard severity/hazard probability (Risk Assessment Code) of IIE, IIID, IVB or less, as defined by the following matrix:

MIL-PRF-32432(GL)

TABLE I Decision authority matrix

HAZARD SEVERITY		HAZARD PROBABILITY				
		Frequent	Reasonably Probable	Occasional	Remote	Improbable
		A	B	C	D	E
Catastrophic	I	***** ** ***HIGH* ***** ***	***** *** ***** ***** *****	***** *** ***** ***** *****	***** ** ***** ***** *****	
Critical	II	***** *** ***** ***** *****	***** *** ***** ***** *****	***** *** ***** ***** *****		..... ..... .....
Marginal	III	***** *** ***** ***** *****		MEDIUM	..... ..... .....	..... ..... .....
Negligible	IV		..... ..... .....	..... ..... .....	..... ..... .....	..... ...LOW..... .....

- Areas shaded represent a High risk level
- Areas shaded represent a Medium risk level, and
- Areas shaded represent a Low risk level. Definitions are found in paragraph 6.5.

3.9.2 Prolonged effects. Prolonged wearing of the MCEP system with and without the UPLC containing polycarbonate lenses ranging from -10 to +8 diopters sphere with up to -3.25 diopters of cylinder shall not cause headaches, dizziness, blurred vision, or undue eye strain/fatigue.

3.9.3 Toxicity. The finished MCEP system shall not present a health hazard and shall show compatibility with prolonged, direct skin contact when tested as specified in 4.4.10. Chemicals recognized by the Environmental Protection Agency (EPA) as human carcinogens shall not be used (see 6.2).

3.9.4 Skin irritants. MCEP shall be free of sharp/rough edges, minimize hot spots, and be easy to keep clean/sanitary so as to avoid cuts, abrasion and/or irritation to the skin that could result in infection.



## MIL-PRF-32432(GL)

3.10 Identification and marking. MCEP system components shall be permanently marked in accordance with ANSI Z87.1. Class 1, Class 1a, Class 2, Class 2a, Class 3 and Class 3a eyewear shall include a date clock (indicating month and year of manufacture) on all frames and a date stamp on all lenses. The date stamp on the lens shall be a two digit month followed by a four digit year (e.g. 04/2009). All frames and lenses shall also be marked with a mold and cavity identifier indicating the mold/cavity where the lens and frames came from along with a marking to indicate the manufacturer of the lens. Date clock and date stamp information shall be in a readily accessible location that does not require destruction of the item to find or read the date stamp or date clock. Application of the marking shall not degrade the eyewear's ability to meet the requirements of this specification beyond the required limits nor shall the markings be placed in a location that impinges on the user's field of view. All classes of eyewear shall have the trademarked letters "APEL" marked on the left temporal region of the eyewear once authorized for use. The logo shall be durable for the life of the item, legible and visible when worn with helmets in 3.3.4., and present no hazard to the soldier (e.g. rubbing, snagging) through its manner of construction/placement. Approval to use the logo must be obtained by the Government (PM Soldier Protective Equipment) prior to implementation.

3.10.1 Product identification. Each manufacturer shall include on the APEL eyewear package a standard APEL certification label as shown below. The label shall be displayed on at least two sides and one end of a boxed product totaling three labels or the front surface of a blister packed product. The label may be in the form of an applied sticker or be permanently printed on the container and should be green in color. If a product is removed from the QPL then the use of APEL must immediately be discontinued. The APEL label is required on the final single pack item, replacement frames and lenses but is not required on larger packages containing multiple single pack items.

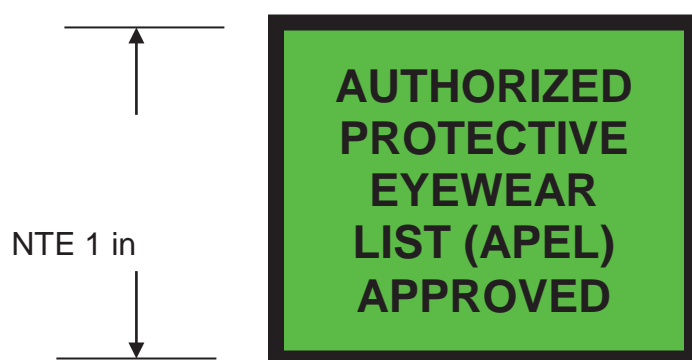

Each manufacturer shall include on the APEL approved eyewear package a statement that states "This product meets the manufacturing and performance testing requirements as authorized by PEO Soldier. This authorization does not constitute an endorsement by the U.S. Army."

## MIL-PRF-32432(GL)

3.10.2 Bar coding. Bar codes (if applicable) shall be as specified in the solicitation and/or contract (see 6.2).

3.11 Compliance with ANSI Z87.1. The eyewear (with and without the UPLC, as applicable) shall be fully compliant with the current edition of ANSI Z87.1 unless otherwise stated. The eyewear shall be assessed as a High Impact Protector. The eyewear shall meet impact protection requirements in all configurations (to include the use of multiple nosepieces to accommodate both prescription and non-prescription wearers). Peripheral protection shall likewise be demonstrated in all configurations. Each type of lens delivered as part of the MCEP system shall be separately tested for the following tests: Penetration, Prismatic Power, Refractive Power/Astigmatism, Resolving Power, Haze, and Transmittance. A minimum of 3 samples shall be used for each test if less than three is specified. Class 3 and 3a items shall be tested to the ANSI Z87.1 goggle requirement.

3.12 Flammability/ignition.

3.12.1 ANSI flammability/ignition. Flammability for the eyewear shall be in accordance with ANSI Z87.1-2003 (flammability) and ANSI Z87.1-2010 (ignition). This shall include any plastic components, such as buckles, that are present on the Class 2, Class 2a, Class 3 and Class 3a retention straps.

3.12.2 Textile flammability. Textile components (not covered by ANSI Z87.1) worn as part of the Class 2, Class 2a, Class 3 and Class 3a eyewear assemblies, to include the retention strap shall be flame resistant. Five samples of each textile component shall be exposed to a vertical flame when tested as specified in 4.4.9. Textile components shall exhibit an average char length no greater than 10 centimeters and shall not exhibit any visible afterflame for greater than 20.0 seconds average after removal from the test flame. It is desired that the protective sleeve on Class 2, Class 2a, Class 3 and Class 3a items also be flame resistant. Textile components shall not exhibit flaming melt-drip. Cleaning cloths and carrying cases are exempt from this requirement.

3.13 Workmanship. MCEP system shall be free from all defects which would affect proper functioning in service. Parts (zippers, snaps, hook and pile, glides, drawstrings, adjustable eyewear features, etc.) shall function properly. Component interfaces shall be secure. All components shall be present. Stitching shall be complete and secure (i.e., no loose/broken/missing stitching). Components shall be free of rough/sharp edges. Lenses shall minimize imperfections, scratches, etc.

#### 4. VERIFICATION

**NOTE:** All verifications pertain to Class 1, Class 2 and Class 3 MCEP system unless otherwise specified. All numerical results shall be rounded out to the same decimal place or whole number as the requirement.

## MIL-PRF-32432(GL)

4.1 Classification of inspections. The inspection requirements specified herein are classified as follows:

- a. Qualification inspection (see 4.1.1).
- b. Conformance inspection (see 4.1.2).
- c. First article inspection (see 4.2)

4.1.1 Qualification inspection. The eyewear shall be subjected to the Examinations and required to pass as specified in 4.1.2.2 and TABLE II. The eyewear shall be subjected to the Verifications indicated by an “x” in the Qualification Column of TABLE III. Qualification requirements are further subdivided into Technical Verification and User Evaluation. Failure to meet any of the tests in 4.1.2.2 and Table II and qualification tests of Table III shall be considered failure of the verification.

4.1.1.1 User evaluation. As part of the Qualification inspection, the eyewear will be subjected to a Field User Evaluation. Users shall wear the eyewear while performing unit training, weapons firing, field exercises, and other representative tasks. Field testing of spectacles and goggles shall include an assessment of fit, comfort, stability, compatibility with equipment, appearance, field of view, ability to sight & fire weapons and use optical augmentation, ability to use mission equipment, ease of changing lenses, ease of fit, durability, resistance to fogging, ease of cleaning, minimization of glint and glare, adequacy/design of carrying case, adequacy of instruction booklet, adequacy and use of anti-fog application, UPLC compatibility (as applicable), and overall user acceptance/preference. Goggles will also be assessed for seal, adequacy of strap, ease of adjusting strap, and wind/dust protection. Upon completion of the User Evaluation, the user’s will score the eyewear on each requirement indicated by an “x” in the “User Eval” column of Table III. The scores will be on a scale of “1” (Very Poor), “2” (Poor), “3” (Neutral), “4” (Good), and “5” (Very Good).

4.1.1.2 Qualification retention. As part of the Qualified Product List (QPL) procedures for the Eyewear, the Eyewear will be subjected to the verifications indicated with an “x” in the “Qual Retention” column of TABLE III every two years. Failure to meet any of the tests in Table III for qualification retention shall be considered failure of the qualification retention and the product will be subject to removal from the QPL.

4.1.1.3 Order of inspection. Perform chemical resistance, adhesion, abrasion, and ballistic fragmentation tests last, as these are destructive tests.

4.1.2 Conformance inspection. Conformance inspection shall include the examination in accordance with 4.1.2.2 and end item testing in accordance with 4.1.2.3. Sampling for inspection shall be performed in accordance with ANSI/ASQ Z1.4 and with the Acceptance Quality Limit (AQL) as specified in the contract and/or order, except where otherwise indicated (see 6.2).

4.1.2.1 Inspection conditions. Unless otherwise specified, all inspections shall be performed in accordance with all the requirements of referenced documents, unless

## MIL-PRF-32432(GL)

otherwise excluded, amended, modified or qualified in this specification or applicable procurement document.

4.1.2.2 Examinations. Sampling for examination shall be in accordance with ANSI/ASQ Z1.4 or the purchase document. Unless otherwise indicated in the purchase document, the Inspection Level shall be I. Samples selected shall be subjected to the Examinations as specified in 4.3 and Table II.

4.1.2.3 Tests. Samples for testing will be as selected as indicated below and subjected to the Verifications indicated by an “x” in the “Conformance” column of Table III. Failure of any test shall be cause for Rejection of the lot. All verification tests shall be conducted on a minimum sample size of three, unless otherwise specified in this document or reference standards (ANSI Z87.1). If the sample size specified in reference standards is less than three then three samples shall be used. Ballistic fragmentation testing, requires a minimum sample size of ten (10) for initial (pre-exposure) ballistic fragmentation testing , and a minimum sample size of three (3) for post exposure ballistic testing. Flame testing on textiles requires a minimum sample size of five (5) in each direction of the material, with the exception of the goggle strap which shall require a minimum sample size of five (5) in the lengthwise direction only.

A Sample Unit for conformance testing shall be comprised of sixty (60) eyewear systems for each configuration being tested to ensure adequate quantity of product to conduct all tests. For the purposes of flame testing, previously tested items (such as high velocity impact items) may be used. Product may be disassembled/reassembled prior to test to verify product dimensions are uniform and interchanging components does not cause a degradation in system performance beyond performance requirements. If a product design incorporates removable/optional components (such as removable facefoam or UPLC adaptors), then all configurations shall be tested and sufficient samples shall be pulled for each. If multiple lenses are incorporated as part of the system, the quantity of optical tests (to include, but not limited to, ANSI optics) conducted on each lens type shall be based on the total number of each lens type contained within the lot, Frames used for optical testing may be re-used for the purposes of testing different lens types in order to minimize the amount of product used up in testing.

The number of Sample Units selected shall be determined by the lot size as indicated below:

<u>Lot Size</u>	<u>Sample Units</u>
0 – 10,000	1
10,001 – 40,000	2
40,001 – 80,000	3

Lot size shall not exceed 80,000. Any additional quantity over 80,000 shall be treated as a new lot.

## MIL-PRF-32432(GL)

4.2 First article inspection. First article sampling shall be submitted in accordance with 4.1.2.3 and subjected to the verifications specified in section 4.1.2.2 and indicated with an “x” in the “Qual Retention” column of TABLE III. Failure to pass any of the tests in TABLE III or visual examination shall be considered failure of the first article.

4.3 End item visual examination. End items shall be examined for the visual defects listed in Table II. Any defect found in an end item listed in Table II shall be considered failure of the visual inspection. Visual inspection of the lens for imperfections, scratches, etc. shall consist of holding the lens approximately 45 centimeters from the eye with the lens viewed against a black background, then a white background, both illuminated by a white light. Initial assessment may be made by subjective examination by a trained individual, or by a comparison to the Eastman-Kodak Scratch and Dig Paddle or equivalent. If required, final assessment shall be made using an optical comparator with a reticule scale of 0.20 millimeters gradations. Defects that are hidden after final assembly, such as those masked by the eyewear frame, will not be scored. The end items shall be examined for the following defects:

4.3.1 Imperfections. An imperfection is defined as a pit, bubble, speck, or dig. Dimensions are measured from the diameter of a circular imperfection or the largest dimension of a non-circular imperfection.

4.3.1.1 Critical area. The critical area (defined by a circle having a 20 millimeters radius centered on the horizontal centerline and 32 millimeters from the vertical centerline) shall not contain more than four imperfections as follows:

- a. One (1) imperfection from 0.21 millimeters to 0.30 millimeters and three imperfections from 0.15 millimeters to 0.20 millimeters.
  - b. OR Four (4) imperfections from 0.15 millimeters to 0.20 millimeters.
- The critical area shall not contain any imperfections larger than 0.30 millimeters.

Imperfections larger than 0.15 millimeters must be separated by 20 millimeters. Any number of imperfections less than 0.15 millimeters are allowed. Imperfections less than 1 millimeters apart, including those less than 0.15 millimeters, shall be scored together (sizes added) as one imperfection.

4.3.1.2 Non-critical area. The non-critical area (all optical surfaces other than the critical optical areas) shall not contain more than thirty (30) imperfections as follows:

- a. Ten (10) imperfections from 0.21 millimeters to 0.40 millimeters and twenty (20) imperfections from 0.15 millimeters to 0.20 millimeters.
- b. OR Thirty (30) imperfections from 0.15 millimeters to 0.20 millimeters.

The non-critical area shall not contain any imperfections larger than 0.40 millimeters.

## MIL-PRF-32432(GL)

Imperfections larger than 0.30 millimeters must be within 10 millimeters of the edge of the lens. Imperfections from 0.21 millimeters to 0.40 millimeters must be separated from each other by at least 20 millimeters and imperfections from 0.15 millimeters to 0.20 millimeters must be separated from each other and any larger imperfections by 10 millimeters. Any number of imperfections less than 0.15 millimeters are allowed. Imperfections less than 1 millimeters apart, including those less than 0.15 millimeters, shall be scored together (sizes added) as one imperfection.

4.3.2 Scratches. The critical area shall not contain any scratches. The non-critical area shall not contain any scratches exceeding the size 40 width defined by the Eastman-Kodak Scratch and Dig Paddle. Acceptable scratches shall not exceed 10 millimeters in length. Multiple scratches must be separated by at least 80 millimeters.

4.3.3 Cloudiness, scuffs, runs. The critical area shall not contain any areas of cloudiness, scuffs, coating lines, coating runs, or areas of partial coating unless the anomaly is within 2 millimeters of the lens edge. The non-critical area shall not contain any areas of cloudiness, scuffs, coating lines, coating runs, or areas of partial coating unless the anomaly is within 3 millimeters of the lens edge.

## MIL-PRF-32432(GL)

TABLE II. End item visual defects

Examine	Defect
Eyewear Quality of material	More than 4 imperfections greater than or equal to 0.15 mm in critical area
	More than one 0.21 mm to 0.30 mm imperfections in critical area
	Any imperfection larger than 0.30 mm in critical area
	Any pair of imperfections greater than or equal to 0.15 mm separated by less than 20 mm in critical area
	More than 10 imperfections from 0.21 mm to 0.40 mm in non-critical area
	More than 30 imperfections greater than or equal to 0.15 mm in non-critical area
	Any imperfection larger than 0.40 mm in the non-critical area
	Any pair of imperfections greater than 0.20 mm separated by less than 20 mm in non-critical area
	Any pair of imperfections greater than or equal to 0.15 mm separated by less than 10 mm in non-critical area
	Any imperfections larger than 0.30 mm not within 10 mm of the edge of the lens in non-critical area
	Break, crack or fracture
	Sharp/rough edges (enough to cause skin abrasion)
	Any scratch in the critical area
	Any scratch greater size 40 in the non-critical area
Any scratch greater than 10mm in length in the non-critical area	

## MIL-PRF-32432(GL)

TABLE II. End item visual defects - Continued

Examine	Defect
Continued - Eyewear Quality of material -	Any pair of scratches not separated greater than or equal to 80 mm
Case-quality of material	Crazing, cracks, warped sidewalls, off shade, mottled or streaky
Workmanship and assembly of eyewear	Any component missing
	Component malformed, warped, chipped or otherwise damaged
	Not connected or joined as specified or assembly is poorly accomplished
Instruction booklet	Instruction booklet missing
	Instruction booklet not in one piece

4.4 Verification

4.4.1 Verification methods. The types of verification methods included in this section are visual inspection, measurement, sample tests, demonstration tests, engineering evaluation, component properties analysis, and similarity to previously-approved or previously-qualified designs. A summary of the verification methods is given in TABLE III.



## MIL-PRF-32432(GL)

TABLE III. Verification methods

Requirement	Requirement Paragraph	Verification Paragraph	Qualification Inspection		Qual Retention (Recertification)	Conformance
			Tech	User Eval		
SYSTEM CONFIGURATION	3.5	4.4.2				
General	3.5.1	4.4.2.1	X		X	X
Eyewear	3.5.1.1	4.4.2.1.1	X		X	X
Color	3.5.1.1.1	4.4.2.1.1.1	X		X	
Carrying Case	3.5.1.2	4.4.2.1.2, 4.4.4.4.2	X		X	X
Instruction Booklet	3.5.1.3	4.4.2.1.3	X		X	X
System Retention	3.5.1.4	4.4.2.1.4		X		
Component Changes	3.5.1.5	4.4.2.1.5		X		
Uniformity in Sys. Dim.	3.5.1.6	4.4.2.1.6	X		X	X
System Weight	3.5.2	4.4.2.2	X		X	X
System Interface Reqts.	3.5.3	4.4.2.3				
ACH and ECH Helmet	3.5.3.1	4.4.2.3.1		X		
CVC Helmet	3.5.3.2	4.4.2.3.2		X		
Hearing Protection Loss	3.5.3.2	4.4.2.3.2.1	X			
LWH Helmet	3.5.3.3	4.4.2.3.3		X		
Weapons	3.5.3.4	4.4.2.3.4		X		
Optics/Displays	3.5.3.5	4.4.2.3.5		X		
Environ. Prot. Clothing	3.5.3.6	4.4.2.3.6		X		
Prescription Lens	3.5.3.7	4.4.2.3.7	X		X	X
MATERIAL/ CHARACTERISTICS	3.6	4.4.3				
Mildew Resistance	3.6.1	4.4.3.1	X		*	
Chemical Resistance	3.6.2	4.4.3.2	X		X	
Ballistic Fragmentation Characteristics	3.6.3	4.4.3.3	X		X	X
Optical Characteristics	3.6.4	4.4.3.4				
Luminous transmittance	3.6.4.1.1	4.4.3.4.1.1, 4.4.3.4.1.2	X		X	X
Neutrality	3.6.4.1.2	4.4.3.4.1.4	X		X	X
Chromaticity	3.6.4.1.3	4.4.3.4.1.5	X		X	X
Field of View ( <u>with</u> and <u>without</u> UPLC)	3.6.4.2	4.4.3.4.2		X		
Resistance to Temporary or Permanent Optical Degradation	3.6.4.3	4.4.3.4.3				
Abrasion	3.6.4.3.1	4.4.3.4.3.1	X		X	X
Fogging	3.6.4.3.2	4.4.3.4.3.2		X		
Prismatic Power	3.6.4.4	4.4.3.4.4	X		X	X

## MIL-PRF-32432(GL)

TABLE III. Verification methods - Continued

Requirement	Requirement Paragraph	Verification Paragraph	Qualification Requirements		Qual Retention (Recertification)	Conformance
			Tech	User Eval		
Optical distortion	3.6.4.5	4.4.3.4.5	X		X	X
Ultraviolet absorption	3.6.4.6	4.4.3.4.6	X		X	X
DURABILITY	3.7	4.4.4				
Carrying Case Protection	3.7.1	4.4.4.1	X			
Service Life/Shelf Life	3.7.2	4.4.4.2	X		*	
Repair	3.7.3	4.4.4.3	X			X
Environment	3.7.4	4.4.4.4				
Eyewear	3.7.4.1	4.4.4.4.1				
- Temperature	3.7.4.1.1	4.4.4.4.1.1	X		*	
- Solar Radiation	3.7.4.1.2	4.4.4.4.1.2	X		*	
- Humidity	3.7.4.1.3	4.4.4.4.1.3	X		*	
- Adhesion	3.7.4.1.4	4.4.4.4.1.4	X		X	X
- Wind/Dust	3.7.4.1.5	4.4.4.4.1.5		X		
- Salt Water	3.7.4.1.6	4.4.4.4.1.6	X			
HUMAN FACTORS	3.8	4.4.5				
Fit/Adjustment	3.8.1	4.4.5.1				
- Sizing/Fit	3.8.1.1	4.4.5.1.1		X		
- Pantoscopic tilts and faceform angles	3.8.1.2	4.4.5.1.2	X			
- Adjustment	3.8.1.3	4.4.5.1.3		X		
Comfort	3.8.2	4.4.5.2		X		
Donning/Doffing	3.8.3	4.4.5.3		X		
Use	3.8.4	4.4.5.4		X		
User Survivability	3.8.5	4.4.5.5		X		
SAFETY/HEALTH HAZARDS	3.9	4.4.6		X		
Prolonged effects	3.9.2	4.4.5.2		X		
Toxicity	3.9.3	4.4.10	X			
Skin Irritants	3.9.4	4.4.6	X	X	X	X
IDENTIFICATION AND MARKING	3.10	4.4.7	X		X	X

\* The Government may perform, or request these tests be performed, periodically to re-verify compliance with specification requirements.

## MIL-PRF-32432(GL)

TABLE III. Verification methods - Continued

Requirement	Requirement Paragraph	Verification Paragraph	Qualification Requirements		Qual Retention (Recertification)	Conformance
			Tech	User Eval		
COMPLIANCE WITH ANSI Z87.1	3.11	4.4.8				
ANSI Z87.1 2010	3.11.	4.4.9.1	X		X	X
FLAMMABILITY	3.12	4.4.9				
ANSI Flammability	3.12.1	4.4.9.1	X		X	
ANSI Ignition	3.12.1	4.4.9.1	X		X	
Textile Flammability	3.12.2	4.4.9.2	X		X	X
WORKMANSHIP	3.13	4.4.11	X		X	X

4.4.1.1 Verification alternatives. The manufacturer may propose alternative test methods, techniques, or equipment, including the application of statistical process control, tool control, or cost-effective sampling procedures to verify performance. Any alternative test method, technique or equipment must be approved by the Government prior to implementation.

#### 4.4.2 System configuration verification.

4.4.2.1 General. Complete each verification in this section. Each eyewear system shall be visually inspected for the components listed in section 3.5.1. Failure to have any of the components of 3.5.1 shall constitute failure of this verification.

4.4.2.1.1 Eyewear. Complete each verification in 4.4.3.3, 4.4.3.4 and 4.4.8. The eyewear shall also be visually examined for the number of protective lenses provided, Classes 1a, 2a and 3a shall also be verified for compatibility with the UPLC”  
Rationale: Clarification of inspection. Failure of any of the verifications, incorrect number of protective lenses or in-ability to be compatible with the UPLC shall constitute failure of this verification.

4.4.2.1.1.1 Color. The color and appearance of the eyewear frames, cases, straps and sleeves shall match the standard sample when viewed using the AATCC Evaluation Procedure 9, Option A, with sources simulating artificial daylight D75 illuminant with a color temperature of 7500 ( $\pm 200$ )°K illumination of 100 ( $\pm 20$ ) foot candles, and shall be a good match to the standard sample under incandescent lamplight at 2856 ( $\pm 200$ )°K. Failure to match the standard sample shall be considered a failure of this verification.

4.4.2.1.2 Carrying case. Demonstrate carrying case carrying capacity by placing the components specified in 3.5.1.2 into the carrying case. Visually examine the carrying case for a means of drainage. Visually and physically manipulate the carrying case for function and to determine the presence of a means for attaching/detaching the carrying case to/from the soldier's belt, vest and packs. Demonstrate accessibility by opening the carrying case and removing/storing components while the carrying case is attached to

## MIL-PRF-32432(GL)

each an equipment belt, vest and pack (inability to store/remove components shall be considered a failure). Nonconformance to 3.5.1.2 shall constitute failure of this verification.

4.4.2.1.3 Instruction booklet. Visually examine the instruction booklet and determine compliance with the requirements of 3.5.1.3. Nonconformance to 3.5.1.3 shall constitute failure of this verification.

4.4.2.1.4 System retention. System Retention will be assessed as part of the User Evaluation. Class 1 and Class 1a shall be assessed both with and without the optional retention strap. At the end of the User Evaluation tasks, participating soldiers will rate the retention capability of the MCEP system while performing representative soldier tasks. An average score of “3” or higher from participating soldiers is required for successful completion of this verification. An average score of less than 3 for this test combined with an overall average score of less than 3 in all areas, or an average score of less than 2 for this test (regardless of the overall average score), shall be cause for rejection.

4.4.2.1.5 Component changes. As part of the User Evaluation, soldiers shall change out eyewear components such as frames, lenses, nosepieces, retention straps and install the UPLC, without the aid of tools, required to perform their tasks. At the end of the User Evaluation tasks, participating soldiers will rate ability of the MCEP system design to change configurations. An average score of “3” or higher from participating soldiers is required for successful completion of this verification. An average score of less than 3 for this test combined with an overall average score of less than 3 in all areas, or an average score of less than 2 for this test (regardless of the overall average score), shall be cause for rejection.

4.4.2.1.6 Uniformity in system dimensions. The end items shall be examined for uniform dimensions between items of the same class, size and product. Samples from the same class, size and product shall be disassembled to a principal component stage, and the components randomly interchanged with components of other systems within the sample. The disassembly and reassembling cycle shall be repeated for three cycles ending on reassembling. UPLC, and any associated adaptors, shall also be included as part of this examination to verify consistency of interface points between the baseline eyewear and the UPLC. Inability to correctly disassemble and reassemble or inability to meet system requirements after interchanging components shall constitute a failure of this verification. If the failure is between the UPLC and the associated adapter, then the dimensions shall be measured at the interface of each part and recorded. Parts that are dimensionally out of tolerance shall be cause for failure for that component.

4.4.2.2 System weight. The MCEP system eyewear shall be weighed by scale for compliance with the requirements of 3.5.2. The MCEP system carrying case (empty) shall be weighed by scale for compliance with the requirements of 3.5.2. Nonconformance to 3.5.2 shall constitute failure of this verification.

## MIL-PRF-32432(GL)

4.4.2.3 System interface requirements. Complete each verification in this section.

4.4.2.3.1 Advanced Combat Helmet (ACH) or Enhanced Combat Helmet (ECH). As part of the User Evaluation, the interface with the ACH will be assessed. Representative users shall be selected for fit with all sizes of ACH or ECH. The users will assess the ability to don/doff the helmet while wearing all classes of MCEP system, to don/doff the Class 2, Class 2a, Class 3 and Class 3a MCEP system while wearing a ACH, ability to wear the Class 2, Class 2a, Class 3 and Class 3a MCEP system over the ACH or ECH, to rotate and tilt the head while wearing the eyewear with the ACH or ECH, and to perform the User Evaluation tasks while wearing the eyewear with the ACH or ECH. Assessments will be made both with and without the UPLC for Classes 1a, 2a and 3a of the MCEP system. At the end of the User Evaluation tasks, participating soldiers will rate interface capability of the MCEP system design with the ACH or ECH. An average score of "3" or higher from participating users is required for successful completion of this verification. An average score of less than 3 for this test combined with an overall average score of less than 3 in all areas, or an average score of less than 2 for this test (regardless of the overall average score), shall be cause for rejection. Any discomfort due to MCEP system noted during the above tasks shall be noted and applied to verification paragraph 4.4.5.2.

4.4.2.3.2 Army Combat Vehicle Crewman (CVC) helmet (DH-132B) and the Marine Corps Advanced CVC helmet. As part of the User Evaluation, the interface with the CVC helmet will be assessed. Representative Users shall be selected for fit with all sizes of CVC helmet. The Users will assess the ability to don/doff the helmet while wearing all classes of MCEP system, to don/doff the Class 2, Class 2a, Class 3 and Class 3a MCEP system while wearing a CVC helmet, to rotate and tilt the head while wearing the eyewear with the CVC helmet, and to perform the User Evaluation tasks while wearing the eyewear with the CVC helmet. Assessments will be made both with and without the UPLC for Classes 1a, 2a and 3a of the MCEP system. Users will also assess the impact, if any, on the noise attenuation characteristics of the CVC ear cups. The change in apparent loudness should be, at most, barely perceptible. At the end of the User Evaluation tasks, participating soldiers will rate interface capability of the MCEP system design with the CVC helmet. An average score of "3" or higher from participating soldiers is required for successful completion of this verification for the Class 2 and Class 3 MCEP system. An average score of less than 3 for this test combined with an overall average score of less than 3 in all areas, or an average score of less than 2 for this test (regardless of the overall average score), shall be cause for rejection. Any discomfort due to MCEP system noted during the above tasks shall be noted and applied to verification paragraph 4.4.5.2.

4.4.2.3.2.1 Hearing protection loss. Class 1 and 1a spectacles claiming compatibility with the CVC helmet and Marine Corps Advanced CVC helmet shall be tested for hearing protection loss in accordance with ANSI S12.42. A hearing loss of greater than 5 decibels shall be considered failure of this verification and the product will not be approved for use with CVC helmets. Class 2, Class 2a, Class 3 and 3a shall be visually inspected to ensure they do not break the ear cup seal when worn over the helmet.

## MIL-PRF-32432(GL)

4.4.2.3.3 Lightweight helmet (LWH). As part of the User Evaluation, the interface with the LWH will be assessed. Representative soldiers shall be selected for fit with all sizes of LWH. The soldiers will assess the ability to don/doff the helmet while wearing all classes of MCEP system, to don/doff the Class 2, Class 2a, Class 3 and Class 3a MCEP system while wearing a LWH, ability to wear the Class 2, Class 2a, Class 3 and Class 3a MCEP system over the LWH, to rotate and tilt the head while wearing the eyewear with the LWH, and to perform the User Evaluation tasks while wearing the eyewear with the LWH. Assessments will be made both with and without the UPLC for Classes 1a, 2a and 3a of the MCEP system. At the end of the User Evaluation tasks, participating soldiers will rate interface capability of the MCEP system design with the LWH. An average score of “3” or higher from participating soldiers is required for successful completion of this verification. An average score of less than 3 for this test combined with an overall average score of less than 3 in all areas, or an average score of less than 2 for this test (regardless of the overall average score), shall be cause for rejection. Any discomfort due to MCEP system noted during the above tasks shall be noted and applied to verification paragraph 4.4.5.2.

4.4.2.3.4 Weapons. As part of the User Evaluation, an assessment will be made by the user on their the ability to shoulder, aim, fire at, hit targets, and carry the weapons stated in section 3.5.3.4 while wearing all classes of MCEP (with or without the UPLC for Class 1a, 2a and 3a). Participating soldiers will rate their ability to perform any of the above tasks while wearing MCEP system. An average score of “3” or higher from participating soldiers is required for successful completion of this verification. An average score of less than 3 for this test combined with an overall average score of less than 3 in all areas, or an average score of less than 2 for this test (regardless of the overall average score), shall be cause for rejection.

4.4.2.3.5 Optics/displays. As part of the User Evaluation, an assessment will be made by the user on their the ability to successfully operate and use optics and displays stated in section 3.5.3.5 while wearing all classes of MCEP (with or without the UPLC for Class 1a, 2a and 3a) Participating users will rate their ability to perform any of the above tasks while wearing MCEP system. An average score of “3” or higher from participating users is required for successful completion of this verification. An average score of less than 3 for this test combined with an overall average score of less than 3 in all areas, or an average score of less than 2 for this test (regardless of the overall average score), shall be cause for rejection.

4.4.2.3.6 Environmental protective clothing. As part of the User Evaluation, the ability to don and doff MCEP system while wearing the Gen III Extreme Cold Weather Clothing System (ECWCS) Parka and Balaclava will be assessed. Participating users will rate their ability to perform any of the above tasks while wearing MCEP system. An average score of “3” or higher from participating users is required for successful completion of this verification. An average score of less than 3 for this test combined with an overall average score of less than 3 in all areas, or an average score of less than 2 for this test (regardless of the overall average score), shall be cause for rejection.

## MIL-PRF-32432(GL)

4.4.2.3.7 Prescription lenses. Two pair of prescription lenses shall be used for evaluation. One prescription of -10 diopters, and one prescription of +8 diopters shall be sized and fitted into the UPLC for the MCEP system. Each diopter UPLC shall be inserted and removed from the MCEP system. Each MCEP system shall be donned and doffed with each diopter UPLC. Inability to mechanically insert and remove the filled prescription into the MCEP system, or mechanically don and doff the MCEP system with each prescription, shall be considered a failure of this verification.

4.4.3 Materials/characteristics verification. All tests shall be performed in a standard atmosphere of 68°F (±10°F) and 50% (±20%) relative humidity, unless otherwise specified.

4.4.3.1 Mildew resistance. The eyewear textile materials to include the carrying case shall be visually inspected for signs of mildew after storage per paragraph 3.6.1. Any visual indication of mildew shall be considered a failure of this verification. An average score of less than 3 for this test combined with an overall acceptability score of less than 3, or an average score of less than 2 for this test (regardless of the overall acceptability score), shall be cause for rejection.

4.4.3.2 Chemical resistance. The front surface of the lens shall be exposed to each of the specified chemicals in section 3.6.2. A new lens shall be used for each new chemical and testing shall be conducted on a sample size of three (3) for each chemical. To expose the lens, the chemical shall be “painted on” or applied to the lens in such a way that the entire critical area (defined by a circle having a 20 millimeters radius centered on the horizontal centerline and 32 millimeters from the vertical centerline) becomes exposed. An absorptive barrier may be used upon application to help prevent chemical run-off to the edge or back surface of the lens. As an alternative, the chemical may be contained within an O-ring (18mm in diameter or more) sealed to the surface of the lens (centered within the critical area) using silicone grease or white glue such that the entire area within the o-ring becomes exposed.

The exposed lens shall then be allowed to sit undisturbed in an area with minimal draft for a 24 hour period. At the end of the test period, the location of the chemically exposed area shall be marked, the O-ring removed (if used), and the surface of the lens rinsed and then dried with compressed air or a non scratching non linting cleaning cloth. Lenses that don't rinse clean with water alone may be cleaned using Dawn Dishwashing Detergent (original scent, NON-ultra) in a ratio of 8 grams of detergent per 1 liter of water by rubbing the lens with the thumb or a non scratching non linting cleaning cloth rinsed with running water and dried with compressed air or a non scratching non linting cleaning cloth. Once dry, samples shall then be inspected in the critical optical area for any obvious visible damage within a 6 mm radius circle centered in the critical optical area and for optical distortion in the same region (see 4.4.3.4.5). Observations shall be recorded. If, within the specified area, obvious visual damage beyond specification requirements is present or the sample is unable to meet the optical distortion requirements of 3.6.4.5, this shall be considered a failure of the verification and testing may be stopped. Products that successfully pass the visual examination and optical distortion testing shall then be tested for ballistic fragmentation impact characteristics in accordance

## MIL-PRF-32432(GL)

with 4.4.3.3 except the impact of the lens shall be limited to one impact within each chemically exposed area. Inability to meet the ballistic fragmentation protection requirements of 3.6.3, obvious visible lens degradation beyond specification requirements, or inability to meet optical distortion requirements of 3.6.4.5 after exposure shall constitute failure of this verification.

#### 4.4.3.3 Ballistic fragmentation characteristics

4.4.3.3.1 Test fixtures. An EN small head form shall be used for those items designated as fitting small faces as declared by the manufacturer and an EN medium head form shall be used for all other items when conducting ballistic testing. Head forms shall be a hardness of 50 + -5 IRHD and on a test fixture mounting, or stand support that is capable of restraining the head form supporting the test item, and withstanding shock resulting from ballistic impact. The fixture, stand, or mounting shall be capable of adjustment for moving the test specimen in the vertical or horizontal positions so that the point of impact can be located anywhere on the test specimen, and rotation on the vertical axis so that the correct obliquity for the test specimen can be achieved anywhere on the test specimen. A 0.05 mm thick aluminum foil witness sheet shall be mounted on the head form, situated 16 mm back from the nasal bridge and behind the area of impact of the critical area. The integrity of the witness foil shall be inspected after all impacts, and the foil replaced if wear/tear is observed. The witness sheet for the medium EN head form shall be in the shape of an ellipse; the major (horizontal) axis of the ellipse shall be 40 mm in width, and the minor (vertical) axis shall be 34 mm in height. The distance between ellipse centers shall be approximately 64 mm so that each witness sheet is centered over each eye of the head form. The witness sheet for the small EN head form shall be in the shape of an ellipse; the major (horizontal) axis of the ellipse shall be 33 mm in width, and the minor (vertical) axis shall be 26 mm in height. The distance between ellipses centers shall be approximately 54 mm so that each witness sheet is centered over each eye of the head form. Unless the eye sockets of the head form have been removed, an air gap shall be created between the witness sheet and the head form surface (minimum 2-mm air gap).

4.4.3.3.2 Velocity measurement. Electronic velocity measurement devices (light beam or acoustic type) shall be used to determine velocity of the projectile. At least a single velocity “time gate” shall be used. Muzzle velocity as measured by the “time gate” shall be corrected using ITOP 4-2-805 to give a strike velocity. Drag coefficients will be provided by the Government for each projectile used. The strike velocity shall be used to determine if a test item has passed or failed ballistic testing. For ballistic testing the velocity measurement instrumentation shall be placed no less than 20 cm (7.8 inches) and no more than 61 cm (24 inches) from the target. The distance is defined as the distance from the middle of the last time gate to the front surface of the item being tested. The velocity measurement devices shall be mounted in such a way that the devices do not move, adjust or shift to ensure consistent measurements. A hit shall be considered fair if the impact velocity is within the specified test range and results in a pass or fail, if the impact velocity is below the test range and results in a fail, or if the impact velocity is above the specified test range and results in a pass.



## MIL-PRF-32432(GL)

4.4.3.3.3 Projectile obliquity and yaw determination. All test projectile impacts shall be at normal incidence (i.e. zero obliquity) to the primary lens. Projectile yaw shall be checked after every shot by performing a visual inspection of the impact location on the test item. A shot shall be “valid” if at least three (3) out of four (4) points of the projectile “chisel” are visible at the point of impact. If this criterion is not met, then the shot shall be considered a misfire and a new test item shall be shot in its place.

4.4.3.3.4 Ballistic fragmentation protection, Class 1. Spectacles shall be hit once with a 0.15 caliber, 5.85 ( $\pm$  0.15) grain, T37 shaped projectile at 640 to 660 ft./sec at normal incidence (0 degree obliquity) to the primary lens at a location within each the left and right critical areas. Impacts shall be alternated between the left and right sides during testing. The critical area is defined as a circle having a 20 mm radius centered on the horizontal centerline and 32 mm from the vertical centerline). A shot shall be considered valid if the projectile hits within the critical area, if the velocity requirements have been met for the shot (i.e., considered “fair” per paragraph 4.4.3.3.2) , if obliquity requirements have been met for the shot, if the impact location is at least two projectile diameters (.76 cm) away from the edge of a lens, and the projectile does not impact the frame. Projectiles shall be a fragment simulating project (FSP) of shape and dimensions as specified in Figure 3 and shall be manufactured from cold rolled, annealed steel conforming to composition 4340H; the projectile hardness shall be Rockwell C30 ( $\pm$  -2). Projectiles will be visually inspected for damage in between each shot. Projectiles may be reused after they have been fired unless visual observation indicates that the projectile has been damaged or deformed. The test item shall be mounted on an EN head form (small or medium) in the as-worn position. Compressed gas propulsion ( $N_2$  or He) of the projectile may be used. The test item shall be removed after each impact for inspection of both the sample and the witness plate and any other observations noted. Damage to the witness sheet or eyewear and all observations (i.e. breakage, cracks, complete dislodgement, partial dislodgement, delamination, flaking, etc.) shall be noted. Ballistic fragmentation testing shall be conducted on a sample size of ten (10) for each configuration tested initially, and a sample size of three (3) for each post exposure (such as post chemical and post environmental). Class 1 and 1a spectacles designed with temple arms shall be tested without the optional retention strap.

The test shall be considered a failure if one or more of the following occur

- 1) if the witness sheet is perforated or if there is a complete penetration of the test item,
- 2) if the primary lens is cracked, fractured, or shattered,
- 3) if one or more fragments become dislodged on the inside of the eyewear (to include coatings)
- 4) if an eyewear component needed to retain the eyewear on the head becomes completely separated from the eyewear
- 5) if the primary lens becomes completely separated from the eyewear
- 6) if the eyewear falls off the head form
- 7) if the inside laminate is cracked and results in a loose flap of material larger than the diameter of the projectile (for laminated lens structures only)

MIL-PRF-32432(GL)

A lens crack is defined as a fissure that propagates beyond the impact site from one surface of the lens to the other. Petalling is not considered a crack.

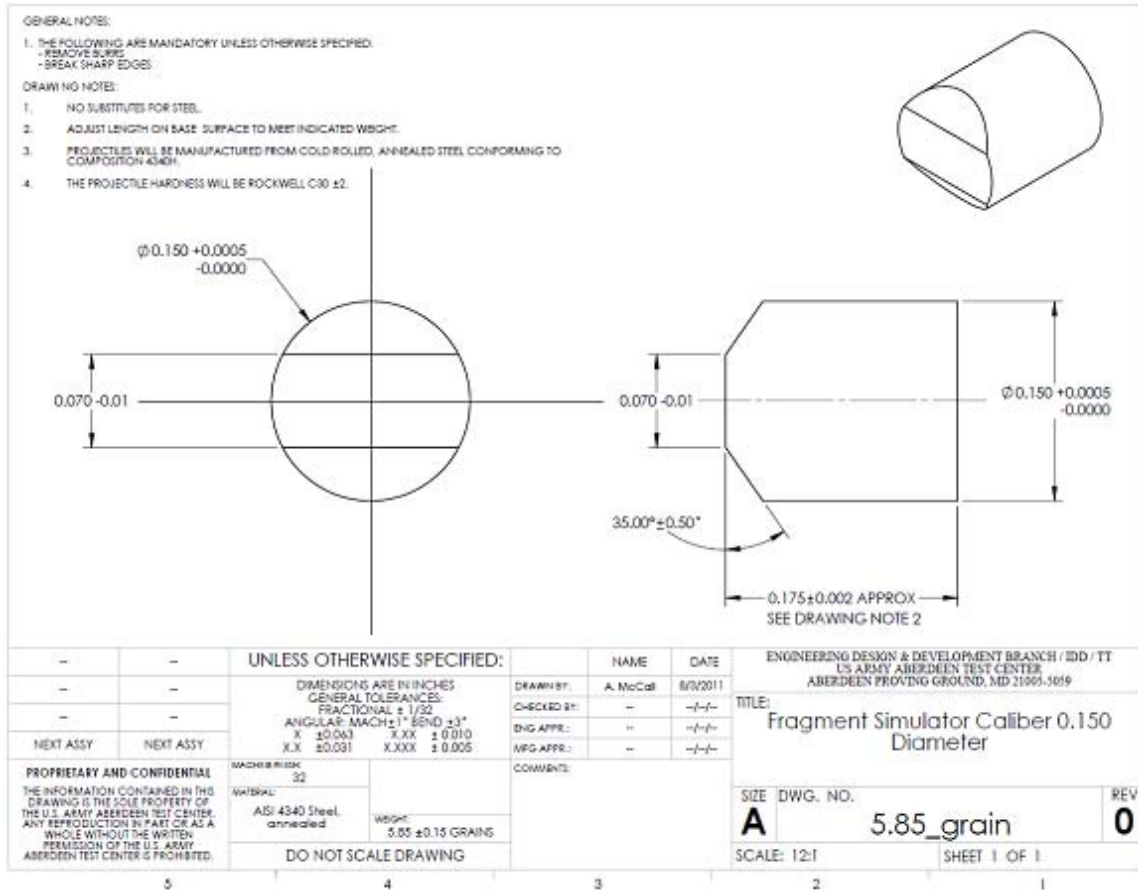

FIGURE 3. Fragment simulator caliber 0.150 diameter

4.4.3.3.5 Ballistic fragmentation protection, Class 2 and Class 3. Class 2 Goggles shall be hit three (3) times with a 0.22 caliber, 17 ( $\pm$  0.5) grain, T37 shaped projectile at 550-560 ft./sec, once on the left side and once on the right with both impacts at normal incidence (0 degree obliquity) to the primary lens at a location within the critical area. The third shot shall be in the center at the vertical center line at normal incidence (0 degree obliquity) to the primary lens. Class 3 shall be impacted in the same manner, with the exception that the center shot shall not be taken. The critical area is defined as a circle having a 20 mm radius centered on the horizontal centerline and 32 mm from the vertical centerline). A shot shall be considered valid if the projectile hits within the critical area or within 10 mm of the designated impact point, if the velocity requirements have been met for the shot (i.e., considered “fair” per paragraph 4.4.3.3.2), if obliquity requirements have been met for the shot, if the impact location is at least two projectile diameters (1.09 cm) away from the edge of a lens, and the projectile does not impact the frame. Projectiles shall be a fragment simulating project (FSP) of shape and dimensions as specified in Figure 4 and shall be manufactured from cold rolled, annealed steel conforming to composition 4340H; the projectile hardness shall be Rockwell C30 ( $\pm$ /-2).

## MIL-PRF-32432(GL)

Projectiles will be visually inspected for damage in between each shot. Projectiles may be reused after they have been fired unless visual observation indicates that the projectile has been damaged or deformed. The test item shall be mounted on an EN head form (small or medium) in the as-worn position. Compressed gas propulsion ( $N_2$  or He) of the projectile may be used. The test item shall be removed after each impact for inspection of both the sample and the witness sheet and any other observations noted. Damage to the witness sheet or eyewear and all observations (i.e. breakage, cracks, complete dislodgement, partial dislodgement, delamination, flaking, etc.) shall be noted. Ballistic fragmentation testing shall be conducted on a sample size of ten (10) for each configuration tested initially, and a sample size of three (3) for each post exposure (such as post chemical and post environmental). The test shall be considered a failure if one or more of the following occur:

- 1) if the witness sheet is perforated or if there is a complete penetration of the test item,
- 2) if the primary lens is cracked, fractured, or shattered,
- 3) if one or more fragments become dislodged on the inside of the eyewear (to include coatings)
- 4) if eyewear component needed to retain the eyewear on the head becomes completely separated from the eyewear
- 5) if the primary lens becomes completely separated from the eyewear
- 6) if the eyewear falls off the head form
- 7) if the inside laminate is cracked and results in a loose flap of material larger than the diameter of the projectile (for laminated lens structures only)

A lens crack is defined as a fissure that propagates beyond the impact site from one surface of the lens to the other. Petalling is not considered a crack.

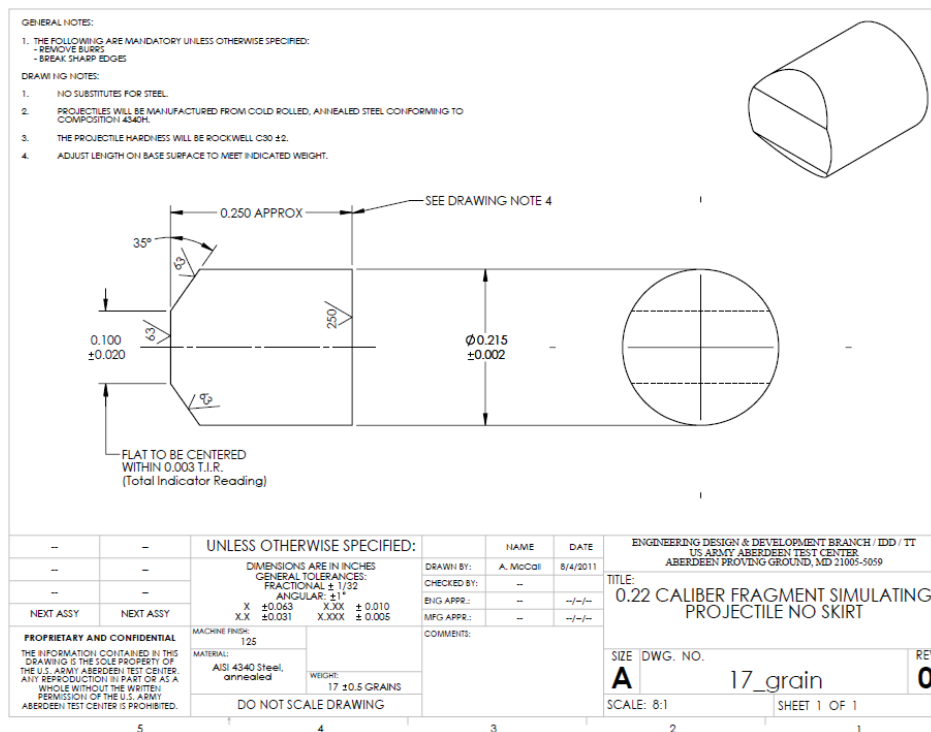

## MIL-PRF-32432(GL)

FIGURE 4. 0.22 Caliber fragment simulating projectile

4.4.3.3.6 Universal Prescription Lens Carrier (UPLC)/adaptors ballistic fragmentation protection Class 1a, Class 2a and Class 3a. Components specific to prescription configurations shall be tested in the prescription configuration for all eyewear it is approved to be used with and shall follow the ballistics testing as defined in sections 4.4.3.3.4 and 4.4.3.3.5 except that the UPLC and prescription lens shall be inspected for damage and dislodgement after each impact and shall be reinstalled/reseated before each impact. Testing with prescription lenses shall include at least one set of polycarbonate prescription lenses consisting of one prescription at +8, one at -10, two at +5, two at -5 diopters, two at +1.5 and two at -1.5 diopters, unless otherwise noted. Damage to the witness sheet, eyewear, UPLC or prescription lens and all observations (i.e. breakage, cracks, complete dislodgement, partial dislodgement, delamination, flaking, etc.) shall be noted.

The test shall be considered a failure if one of the failure mechanisms identified in 4.4.3.3.4 or 4.4.3.3.5 occur (for the respective eyewear under test), or if one or more of the following occur with respect to the prescription lens carrier:

- 1) if the prescription lens is cracked or chipped on the posterior surface;
- 2) or if complete separation of a prescription lens occurs during testing and results in one or more of the following:
  - a) the witness sheet is punctured for any reason;
  - b) or if more than 10% of the total number of impacts result in complete dislodgement of the prescription lens in a sample size of 10 or more test items with the total number of impacts defined as the number of test items multiplied by the number of impacts per test item.
- 3) or, if an adaptor/interface component included as part of the MCEP system for UPLC compatibility is completely dislodged
- 4) or the UPLC is completely dislodged from the MCEP system adaptor /interface component due to inadequate design/quality of the MCEP adapter/interface component. All interface dimensions for both the adaptor/interface component and UPLC shall be measured in this case and recorded. An MCEP adaptor/interface component that is deemed out of tolerance or otherwise insufficient fit to the UPLC dimensions shall be cause for rejection.

A lens crack is defined as a fissure that propagates beyond the impact site from one surface of the lens to the other. Petalling is not considered a crack.

4.4.3.4 Optical tests. Complete each verification in this section. All optical testing shall be conducted in the critical optical area (defined by a circle having a 20 millimeters radius centered on the horizontal centerline and 32 millimeters from the vertical centerline), unless otherwise specified.

4.4.3.4.1 Luminous transmittance/neutrality/chromaticity. The spectral transmittance shall be measured with the use of a spectrophotometer from 380 nanometers (nm) to 780 nanometers in increments of two (2) nanometers or less. The photopic and scotopic

## MIL-PRF-32432(GL)

transmittances shall be calculated according to the methods of 4.4.3.4.1.1 and 4.4.3.4.1.2. Neutrality and Chromaticity shall be measured in accordance with 4.4.3.4.1.4 and 4.4.3.4.1.5. The lens shall be orientated in such a way that the light source impinges the front surface of the lens and the light captured by the aperture is coming from the back surface of the lens.

4.4.3.4.1.1 Method of calculation. Two methods of calculation are provided. Either may be used for the purpose of this verification.

METHOD 1:

The average luminous transmittance T is given by the general relationship

$$T = \frac{1}{k} \int_{380}^{780} T(L) E(L) V(L) dL$$

where

$$k = \int_{380}^{780} E(L) V(L) dL$$

and

T(L) = spectral transmittance of material at wavelength L

E(L) = relative spectral irradiance of source

V(L) = luminous efficiency as a function of wavelength

The spectral transmittance of the sample shall be measured with a spectrophotometer and the integrals computed. A 2 nanometer increment for the integration is recommended, particularly if the source emission bands or the absorption/rejection bands are narrow. The calculations for photopic and scotopic transmittance may be done concurrently with the use of a computer or programmable calculator.

METHOD 2:

The spectral transmittance of the sample shall be measured with a spectrophotometer in increments of 2 nanometers or less.

Using Table IV, the photopic and scotopic transmittances are calculated as follows. The calculations may be done concurrently or with the use of a computer or programmable calculator.

- Multiply  $V\lambda$  by T at each wavelength
- Multiply  $V\lambda'$  by T at each wavelength
- Obtain separate totals for the number in  $V\lambda$ ,  $V\lambda'$ ,  $V\lambda \times T$  and  $V\lambda' \times T$ , columns.
- Sum of  $V\lambda \times T$  column divided by sum of  $V\lambda$  column is the photopic transmittance. Multiply this by 100 to get percent.

## MIL-PRF-32432(GL)

- Sum of  $V\lambda' \times T$  column divided by sum of  $V\lambda'$  column is the scotopic transmittance. Multiply this by 100 to get percent.

Where:  $V\lambda$  = Photopic relative luminosity (CIE 1924 standard)

$V\lambda'$  = Scotopic relative luminosity (CIE 1951 standard)

T = Transmittance of device under test

$T_p$  = Percent photopic transmittance

$T_s$  = Percent scotopic transmittance

For the example data included as part of Table IV, the totals for the columns are as follows:

Sum  $V\lambda$  = 53.4292

Sum  $V\lambda'$  = 48.5375

Sum  $V\lambda \times T$  = 6.7187

Sum  $V\lambda' \times T$  = 1.1691

For this example, the photopic transmittance would be  $(6.7187/53.4291) \times 100 = 12.57\%$  and the scotopic transmittance would be  $(1.1691/48.5375) \times 100 = 2.41\%$

Note that, for the purposes of the actual calculation, the example transmittance numbers (T) in bold type in Table IV shall be replaced by measurements made on the actual device under test. The example  $V(\lambda) \times T$  and  $V'(\lambda) \times T$  in italics in Table IV shall, in turn, be replaced by the product that results from using the actual transmittance numbers of the device under test.

#### 4.4.3.4.1.2 Photopic transmittance. Photopic luminous transmittance $T_p$

(transmittance for the light adapted eye) is calculated either by Method 1 (using for  $V(\lambda)$  the photopic luminous efficiency values and the spectral irradiance function for CIE Illuminant C which are listed in Table IV) or by Method 2 (using  $V(\lambda)$  listed for each wavelength in Table IV). Nonconformance to 3.6.4.1.1 shall constitute failure of this verification.

#### 4.4.3.4.1.3 Scotopic transmittance. Scotopic luminous transmittance $T_s$

(transmittance for the dark adapted eye) shall be calculated either by Method 1 (using for  $V(\lambda)$  the scotopic luminous efficiency values and the spectral irradiance function for CIE Illuminant C which are listed in Table IV) or by Method 2 (using  $V'(\lambda)$  listed for each wavelength in Table IV). Nonconformance to 3.6.4.1.1 shall constitute failure of this verification.

## MIL-PRF-32432(GL)

TABLE IV. Data for transmittance calculations

Wave-length nm	Method 1			Method 2				
	V(L) Photopic	V'(L) Scotopic	E(L) Source Distribution Illuminant C	V( $\lambda$ ) Photopic	V'( $\lambda$ ) Scotopic	Example T	Example $V(\lambda) \times T$	Example $V'(\lambda) \times T$
380	0	5.90	33.00	0.0000	0.0006	<b>0.0000</b>	0.0000	0.0000
382	0	7.90	35.77	0.0000	0.0008	<b>0.0000</b>	0.0000	0.0000
384	1	10.06	38.54	0.0001	0.0010	<b>0.0000</b>	0.0000	0.0000
386	1	13.30	41.42	0.0001	0.0013	<b>0.0000</b>	0.0000	0.0000
388	1	17.70	41.00	0.0001	0.0017	<b>0.0000</b>	0.0000	0.0000
390	1	22.10	47.40	0.0001	0.0022	<b>0.0000</b>	0.0000	0.0000
392	1	31.38	50.51	0.0002	0.0029	<b>0.0000</b>	0.0000	0.0000
394	2	40.66	53.62	0.0002	0.0039	<b>0.0000</b>	0.0000	0.0000
396	2	54.82	56.80	0.0002	0.0052	<b>0.0000</b>	0.0000	0.0000
398	3	73.86	60.05	0.0003	0.0070	<b>0.0000</b>	0.0000	0.0000
400	4	92.90	63.30	0.0004	0.0093	<b>0.0000</b>	0.0000	0.0000
402	5	129.74	66.70	0.0005	0.0123	<b>0.0000</b>	0.0000	0.0000
404	6	166.58	70.11	0.0006	0.0162	<b>0.0000</b>	0.0000	0.0000
406	7	217.68	73.57	0.0007	0.0211	<b>0.0000</b>	0.0000	0.0000
408	10	283.04	77.08	0.0009	0.0273	<b>0.0000</b>	0.0000	0.0000
410	12	348.40	80.60	0.0012	0.0348	<b>0.0000</b>	0.0000	0.0000
412	16	450.64	84.17	0.0015	0.0439	<b>0.0000</b>	0.0000	0.0000
414	20	552.88	87.74	0.0019	0.0545	<b>0.0000</b>	0.0000	0.0000
416	26	676.40	91.24	0.0025	0.0668	<b>0.0000</b>	0.0000	0.0000
418	33	821.20	94.67	0.0031	0.0808	<b>0.0000</b>	0.0000	0.0000
420	40	966.00	98.10	0.0040	0.0966	<b>0.0000</b>	0.0000	0.0000
422	53	1154.00	101.18	0.0052	0.1141	<b>0.0000</b>	0.0000	0.0000
424	66	1342.00	104.26	0.0065	0.1334	<b>0.0000</b>	0.0000	0.0000
426	82	1548.40	107.12	0.0081	0.1541	<b>0.0000</b>	0.0000	0.0000
428	99	1773.20	109.76	0.0098	0.1764	<b>0.0000</b>	0.0000	0.0000

## MIL-PRF-32432(GL)

TABLE IV. Data for transmittance calculations - Continued

Wave-length nm	Method 1			Method 2				
	V(L) Photopic	V'(L) Scotopic	E(L) Source Distribution Illuminant C	V( $\lambda$ ) Photopic	V'( $\lambda$ ) Scotopic	Example T	Example $V(\lambda) \times T$	Example $V'(\lambda) \times T$
430	116	1998.00	112.40	0.0116	0.1998	<b>0.0000</b>	0.0000	0.0000
432	137	2248.80	114.54	0.0136	0.2243	<b>0.0000</b>	0.0000	0.0000
434	158	2499.60	116.68	0.0157	0.2496	<b>0.0000</b>	0.0000	0.0000
436	180	2756.20	118.50	0.0180	0.2755	<b>0.0000</b>	0.0000	0.0000
438	205	3018.60	120.00	0.0205	0.3017	<b>0.0000</b>	0.0000	0.0000
440	230	3281.00	121.50	0.0230	0.3281	<b>0.0000</b>	0.0000	0.0000
442	257	3541.00	122.28	0.0256	0.3543	<b>0.0000</b>	0.0000	0.0000
444	284	3801.00	123.06	0.0284	0.3803	<b>0.0000</b>	0.0000	0.0000
446	314	4054.80	123.56	0.0313	0.4060	<b>0.0000</b>	0.0000	0.0000
448	347	4302.40	123.78	0.0345	0.4310	<b>0.0000</b>	0.0000	0.0000
450	380	4550.00	124.00	0.0380	0.4550	<b>0.0000</b>	0.0000	0.0000
452	420	4781.60	123.84	0.0418	0.4790	<b>0.0000</b>	0.0000	0.0000
454	460	5013.20	123.68	0.0458	0.5020	<b>0.0000</b>	0.0000	0.0000
456	504	5237.60	123.50	0.0502	0.5240	<b>0.0000</b>	0.0000	0.0000
458	552	5454.80	123.30	0.0550	0.5460	<b>0.0000</b>	0.0000	0.0000
460	600	5672.00	123.10	0.0600	0.5670	<b>0.0000</b>	0.0000	0.0000
462	656	5885.20	123.18	0.0653	0.5880	<b>0.0000</b>	0.0000	0.0000
464	711	6098.40	123.26	0.0709	0.6100	<b>0.0000</b>	0.0000	0.0000
466	773	6315.20	123.40	0.0770	0.6310	<b>0.0000</b>	0.0000	0.0000
468	842	6535.60	123.60	0.0837	0.6530	<b>0.0000</b>	0.0000	0.0000
470	910	6756.00	123.80	0.0910	0.6760	<b>0.0000</b>	0.0000	0.0000
472	996	6988.40	123.88	0.0990	0.6990	<b>0.0000</b>	0.0000	0.0000
474	1083	7220.80	123.96	0.1079	0.7220	<b>0.0000</b>	0.0000	0.0000
476	1179	7455.60	123.98	0.1175	0.7450	<b>0.0000</b>	0.0000	0.0000
478	1284	7692.80	123.94	0.1280	0.7690	<b>0.0001</b>	0.0000	0.0000
480	1390	7930.00	123.90	0.1390	0.7930	<b>0.0001</b>	0.0000	0.0001
482	1511	8161.60	123.51	0.1505	0.8170	<b>0.0001</b>	0.0000	0.0000
484	1632	8393.20	123.12	0.1627	0.8400	<b>0.0000</b>	0.0000	0.0000
486	1771	8615.80	122.48	0.1762	0.8620	<b>0.0000</b>	0.0000	0.0000
488	1925	8829.40	121.59	0.1913	0.8840	<b>0.0000</b>	0.0000	0.0000
490	2080	9043.00	120.70	0.2080	0.9040	<b>0.0000</b>	0.0000	0.0000
492	2282	9222.20	119.18	0.2267	0.9230	<b>0.0000</b>	0.0000	0.0000
494	2485	9401.40	117.66	0.2475	0.9410	<b>0.0000</b>	0.0000	0.0000
496	2715	9556.20	115.94	0.2702	0.9570	<b>0.0000</b>	0.0000	0.0000
498	2972	9686.60	114.02	0.2951	0.9700	<b>0.0000</b>	0.0000	0.0000
500	3230	9817.00	112.10	0.3230	0.9820	<b>0.0000</b>	0.0000	0.0000
502	3567	9883.80	110.05	0.3547	0.9900	<b>0.0000</b>	0.0000	0.0000
504	3904	9950.60	108.00	0.3893	0.9970	<b>0.0000</b>	0.0000	0.0000



## MIL-PRF-32432(GL)

TABLE IV. Data for transmittance calculations - Continued

Wave-length nm	Method 1			Method 2				
	V(L) Photopic	V'(L) Scotopic	E(L) Source Distribution Illuminant C	V( $\lambda$ ) Photopic	V'( $\lambda$ ) Scotopic	Example T	Example $V(\lambda) \times T$	Example $V'(\lambda) \times T$
506	4264	9980.40	106.04	0.4256	1.0000	<b>0.0000</b>	0.0000	0.0000
508	4647	9973.20	104.17	0.4634	1.0000	<b>0.0000</b>	0.0000	0.0000
510	5030	9966.00	102.30	0.5030	0.9970	<b>0.0000</b>	0.0000	0.0000
512	5451	9879.60	100.90	0.5445	0.9900	<b>0.0000</b>	0.0000	0.0000
514	5872	9793.20	99.51	0.5870	0.9810	<b>0.0000</b>	0.0000	0.0000
516	6286	9670.40	98.43	0.6293	0.9680	<b>0.0000</b>	0.0000	0.0000
518	6693	9511.20	97.66	0.6709	0.9530	<b>0.0000</b>	0.0000	0.0000
520	7100	9352.00	96.90	0.7100	0.9350	<b>0.0000</b>	0.0000	0.0000
522	7433	9129.60	96.85	0.7455	0.9150	<b>0.0000</b>	0.0000	0.0000
524	7766	8907.20	96.80	0.7778	0.8920	<b>0.0000</b>	0.0000	0.0000
526	8070	8658.80	97.02	0.8081	0.8670	<b>0.0000</b>	0.0000	0.0000
528	8345	8384.40	97.51	0.8363	0.8400	<b>0.0000</b>	0.0000	0.0000
530	8620	8110.00	98.00	0.8620	0.8110	<b>0.0000</b>	0.0000	0.0000
532	8832	7798.80	98.78	0.8850	0.7810	<b>0.0002</b>	0.0001	0.0001
534	9043	7487.60	99.55	0.9054	0.7490	<b>0.0003</b>	0.0003	0.0002
536	9227	7165.00	100.37	0.9237	0.7170	<b>0.0011</b>	0.0010	0.0008
538	9384	6831.00	101.24	0.9399	0.6830	<b>0.0024</b>	0.0022	0.0016
540	9540	6497.00	102.10	0.9540	0.6500	<b>0.0037</b>	0.0035	0.0024
542	9645	6155.80	102.84	0.9660	0.6160	<b>0.0111</b>	0.0107	0.0068
544	9750	5814.60	103.58	0.9760	0.5810	<b>0.0184</b>	0.0180	0.0107
546	9832	5476.80	104.20	0.9841	0.5480	<b>0.0319</b>	0.0314	0.0175
548	9891	5142.40	104.70	0.9903	0.5140	<b>0.0514</b>	0.0509	0.0264
550	9950	4808.00	105.20	0.9950	0.4810	<b>0.0710</b>	0.0706	0.0342
552	9971	4490.80	105.39	0.9981	0.4480	<b>0.1001</b>	0.0999	0.0448
554	9992	4173.60	105.58	0.9997	0.4170	<b>0.1292</b>	0.1291	0.0539
556	9992	3869.60	105.60	0.9999	0.3864	<b>0.1575</b>	0.1575	0.0609
558	9971	3578.80	105.45	0.9983	0.3569	<b>0.1852</b>	0.1849	0.0661
560	9950	3288.00	105.30	0.9950	0.3288	<b>0.2129</b>	0.2118	0.0700
562	9884	3028.40	104.82	0.9897	0.3018	<b>0.2321</b>	0.2297	0.0700
564	9819	2768.80	104.35	0.9827	0.2762	<b>0.2512</b>	0.2469	0.0694
566	9733	2526.40	103.75	0.9741	0.2519	<b>0.2664</b>	0.2595	0.0671
568	9626	2301.20	103.02	0.9639	0.2291	<b>0.2777</b>	0.2676	0.0636
570	9520	2076.00	102.30	0.9520	0.2076	<b>0.2889</b>	0.2750	0.0600
572	9374	1886.40	101.40	0.9385	0.1876	<b>0.2939</b>	0.2758	0.0551
574	9227	1696.80	100.50	0.9235	0.1690	<b>0.2989</b>	0.2760	0.0505
576	9063	1524.00	99.60	0.9070	0.1517	<b>0.3014</b>	0.2734	0.0457
578	8882	1368.00	98.70	0.8892	0.1358	<b>0.3015</b>	0.2681	0.0409
580	8700	1212.00	97.80	0.8700	0.1212	<b>0.3016</b>	0.2624	0.0366
582	8485	1086.80	96.85	0.8494	0.1078	<b>0.2976</b>	0.2527	0.0321

## MIL-PRF-32432(GL)

TABLE IV. Data for transmittance calculations - Continued

Wave-length nm	Method 1			Method 2				
	V(L) Photopic	V'(L) Scotopic	E(L) Source Distribution Illuminant C	V( $\lambda$ ) Photopic	V'( $\lambda$ ) Scotopic	Example T	Example $V(\lambda) \times T$	Example $V'(\lambda) \times T$
584	8270	961.60	95.90	0.8276	0.0956	<b>0.2935</b>	0.2429	0.0281
586	8044	850.20	94.98	0.8048	0.0845	<b>0.2885</b>	0.2322	0.0244
588	7807	752.60	94.09	0.7812	0.0745	<b>0.2824</b>	0.2206	0.0210
590	7570	655.00	93.20	0.7570	0.0655	<b>0.2763</b>	0.2092	0.0181
592	7322	580.60	92.41	0.7324	0.0574	<b>0.2696</b>	0.1975	0.0155
594	7073	506.20	91.62	0.7075	0.0502	<b>0.2629</b>	0.1860	0.0132
596	6821	441.70	90.92	0.6822	0.0438	<b>0.2554</b>	0.1742	0.0112
598	6566	387.10	90.31	0.6567	0.0382	<b>0.2469</b>	0.1621	0.0094
600	6310	332.50	89.70	0.6310	0.0332	<b>0.2384</b>	0.1504	0.0079
602	6053	291.98	89.35	0.6053	0.0287	<b>0.2278</b>	0.1379	0.0065
604	5796	251.46	89.00	0.5796	0.0249	<b>0.2171</b>	0.1259	0.0054
606	5540	216.82	88.74	0.5540	0.0215	<b>0.2049</b>	0.1135	0.0044
608	5285	188.06	88.57	0.5284	0.0185	<b>0.1912</b>	0.1010	0.0035
610	5030	159.30	88.40	0.5030	0.0159	<b>0.1775</b>	0.0893	0.0028
612	4783	139.10	88.32	0.4780	0.0137	<b>0.1623</b>	0.0776	0.0022
614	4536	118.90	88.23	0.4534	0.0118	<b>0.1470</b>	0.0667	0.0017
616	4292	101.78	88.17	0.4291	0.0101	<b>0.1326</b>	0.0569	0.0013
618	4051	87.74	88.14	0.4050	0.0086	<b>0.1191</b>	0.0482	0.0010
620	3810	73.70	88.10	0.3810	0.0074	<b>0.1055</b>	0.0402	0.0008
622	3570	64.10	88.08	0.3568	0.0063	<b>0.0962</b>	0.0343	0.0006
624	3330	54.50	88.07	0.3328	0.0054	<b>0.0869</b>	0.0289	0.0005
626	3098	46.43	88.05	0.3093	0.0046	<b>0.0793</b>	0.0245	0.0004
628	2874	39.89	88.02	0.2866	0.0039	<b>0.0735</b>	0.0211	0.0003
630	2650	33.15	88.00	0.2650	0.0033	<b>0.0677</b>	0.0179	0.0002
632	2458	28.95	87.94	0.2449	0.0028	<b>0.0637</b>	0.0156	0.0002
634	2266	24.55	87.89	0.2261	0.0024	<b>0.0597</b>	0.0135	0.0001
636	2086	20.87	87.85	0.2082	0.0021	<b>0.0560</b>	0.0117	0.0001
638	1918	17.92	87.82	0.1912	0.0018	<b>0.0526</b>	0.0101	0.0001
640	1750	14.97	87.80	0.1750	0.0015	<b>0.0492</b>	0.0086	0.0001
642	1603	13.00	87.88	0.1596	0.0013	<b>0.0462</b>	0.0074	0.0001
644	1456	11.03	87.95	0.1451	0.0011	<b>0.0431</b>	0.0063	0.0000
646	1320	9.39	88.03	0.1315	0.0009	<b>0.0402</b>	0.0053	0.0000
648	1195	8.08	88.12	0.1188	0.0008	<b>0.0375</b>	0.0044	0.0000
650	1070	6.77	88.20	0.1070	0.0007	<b>0.0347</b>	0.0037	0.0000
652	968	5.90	88.20	0.0962	0.0006	<b>0.0319</b>	0.0031	0.0000
654	867	5.03	88.20	0.0863	0.0005	<b>0.0292</b>	0.0025	0.0000
656	775	4.30	88.14	0.0771	0.0004	<b>0.0264</b>	0.0020	0.0000
658	692	3.71	88.02	0.0687	0.0004	<b>0.0235</b>	0.0016	0.0000
660	610	3.13	87.90	0.0610	0.0003	<b>0.0207</b>	0.0013	0.0000

## MIL-PRF-32432(GL)

TABLE IV. Data for transmittance calculations - Continued

Wave-length nm	Method 1			Method 2				
	V(L) Photopic	V'(L) Scotopic	E(L) Source Distribution Illuminant C	V( $\lambda$ ) Photopic	V'( $\lambda$ ) Scotopic	Example T	Example $V(\lambda) \times T$	Example $V'(\lambda) \times T$
662	544	2.74	87.63	0.0540	0.0003	<b>0.0181</b>	0.0010	0.0000
664	479	2.34	87.36	0.0475	0.0002	<b>0.0154</b>	0.0007	0.0000
666	421	2.01	87.04	0.0418	0.0002	<b>0.0129</b>	0.0005	0.0000
668	370	1.75	86.67	0.0366	0.0002	<b>0.0106</b>	0.0004	0.0000
670	320	1.48	86.30	0.0320	0.0001	<b>0.0083</b>	0.0003	0.0000
672	285	1.30	85.90	0.0281	0.0001	<b>0.0065</b>	0.0002	0.0000
674	250	1.12	85.50	0.0247	0.0001	<b>0.0048</b>	0.0001	0.0000
676	220	.96	85.04	0.0218	0.0001	<b>0.0034</b>	0.0001	0.0000
678	195	.84	84.52	0.0193	0.0001	<b>0.0025</b>	0.0000	0.0000
680	170	.72	84.00	0.0170	0.0001	<b>0.0015</b>	0.0000	0.0000
682	150	.63	83.28	0.0148	0.0001	<b>0.0011</b>	0.0000	0.0000
684	129	.54	82.57	0.0128	0.0001	<b>0.0007</b>	0.0000	0.0000
686	112	.47	81.81	0.0111	0.0000	<b>0.0004</b>	0.0000	0.0000
688	97	.41	81.00	0.0095	0.0000	<b>0.0003</b>	0.0000	0.0000
690	82	.35	80.20	0.0082	0.0000	<b>0.0002</b>	0.0000	0.0000
692	72	.31	79.42	0.0071	0.0000	<b>0.0002</b>	0.0000	0.0000
694	62	.27	78.63	0.0061	0.0000	<b>0.0001</b>	0.0000	0.0000
696	54	.24	77.85	0.0053	0.0000	<b>0.0001</b>	0.0000	0.0000
698	47	.21	77.08	0.0047	0.0000	<b>0.0000</b>	0.0000	0.0000
700	41	.18	76.30	0.0041	0.0000	<b>0.0000</b>	0.0000	0.0000
702	36	.16	75.52	0.0036	0.0000	<b>0.0000</b>	0.0000	0.0000
704	31	.14	74.75	0.0031	0.0000	<b>0.0000</b>	0.0000	0.0000
706	27	.12	73.97	0.0027	0.0000	<b>0.0000</b>	0.0000	0.0000
708	24	.11	73.18	0.0024	0.0000	<b>0.0000</b>	0.0000	0.0000
710	21	.09	72.40	0.0021	0.0000	<b>0.0000</b>	0.0000	0.0000
712	19	.08	71.60	0.0020	0.0000	<b>0.0000</b>	0.0000	0.0000
714	16	.07	70.80	0.0017	0.0000	<b>0.0000</b>	0.0000	0.0000
716	14	.06	69.98	0.0015	0.0000	<b>0.0000</b>	0.0000	0.0000
718	12	.06	68.14	0.0013	0.0000	<b>0.0000</b>	0.0000	0.0000
720	10	.05	68.30	0.0011	0.0000	<b>0.0000</b>	0.0000	0.0000
722	9	.04	67.50	0.0010	0.0000	<b>0.0000</b>	0.0000	0.0000
724	8	.04	66.70	0.0009	0.0000	<b>0.0000</b>	0.0000	0.0000
726	7	.03	65.92	0.0007	0.0000	<b>0.0000</b>	0.0000	0.0000
728	6	.03	65.16	0.0006	0.0000	<b>0.0000</b>	0.0000	0.0000
730	5	.03	64.40	0.0006	0.0000	<b>0.0000</b>	0.0000	0.0000
732	5	.02	63.76	0.0005	0.0000	<b>0.0000</b>	0.0000	0.0000
734	4	.02	63.12	0.0004	0.0000	<b>0.0000</b>	0.0000	0.0000
736	4	.02	62.54	0.0004	0.0000	<b>0.0000</b>	0.0000	0.0000
738	3	.02	62.02	0.0003	0.0000	<b>0.0000</b>	0.0000	0.0000

## MIL-PRF-32432(GL)

TABLE IV. Data for transmittance calculations - Continued

Wave-length nm	Method 1			Method 2				
	V(L) Photopic	V'(L) Scotopic	E(L) Source Distribution Illuminant C	V( $\lambda$ ) Photopic	V'( $\lambda$ ) Scotopic	Example T	Example $V(\lambda) \times T$	Example $V'(\lambda) \times T$
740	3	.01	61.50	0.0003	0.0000	<b>0.0000</b>	0.0000	0.0000
742	3	.01	60.98	0.0002	0.0000	<b>0.0000</b>	0.0000	0.0000
744	2	.01	60.46	0.0002	0.0000	<b>0.0000</b>	0.0000	0.0000
746	2	.01	60.00	0.0002	0.0000	<b>0.0000</b>	0.0000	0.0000
748	1	.00	59.60	0.0001	0.0000	<b>0.0000</b>	0.0000	0.0000
750	1	.00	59.20	0.0001	0.0000	<b>0.0001</b>	0.0000	0.0000
752	1	.00	58.92	0.0001	0.0000	<b>0.0001</b>	0.0000	0.0000
754	1	.00	58.64	0.0001	0.0000	<b>0.0000</b>	0.0000	0.0000
756	1	.00	58.42	0.0001	0.0000	<b>0.0000</b>	0.0000	0.0000
758	1	.00	58.96	0.0001	0.0000	<b>0.0000</b>	0.0000	0.0000
760	1	.00	58.10	0.0001	0.0000	<b>0.0001</b>	0.0000	0.0000
762	1	.00	58.06	0.0001	0.0000	<b>0.0001</b>	0.0000	0.0000
764	0	.00	58.02	0.0000	0.0000	<b>0.0000</b>	0.0000	0.0000
766	0	.00	58.04	0.0000	0.0000	<b>0.0000</b>	0.0000	0.0000
768	0	.00	58.12	0.0000	0.0000	<b>0.0000</b>	0.0000	0.0000
770	0	.00	58.20	0.0000	0.0000	<b>0.0000</b>	0.0000	0.0000
772	0	.00	34.92	0.0000	0.0000	<b>0.0000</b>	0.0000	0.0000
774	0	.00	11.64	0.0000	0.0000	<b>0.0000</b>	0.0000	0.0000
776	0	.00	.00	0.0000	0.0000	<b>0.0000</b>	0.0000	0.0000
778	0	.00	.00	0.0000	0.0000	<b>0.0000</b>	0.0000	0.0000
780	0	.00	.00	0.0000	0.0000	<b>0.0000</b>	0.0000	0.0000

4.4.3.4.1.4 Neutrality test. If a configuration providing ballistic fragmentation protection and bright sunlight (sunglass) protection is offered as part of the system, the spectral transmittance shall be measured by a spectrophotometer having a monochromator band width of 10 nanometers or less and a reproduction of plus or minus 1 percent. The neutrality shall be calculated, using the average spectral transmittance over the 520-580 nm band ( $T_c$ ) for comparison. CIE Illuminant C shall be used. Table V shows an example for the calculation of spectral transmittance deviations. Nonconformance to 3.6.4.1.2 shall constitute failure of this verification.

## MIL-PRF-32432(GL)

TABLE V. Example for calculation of spectral transmittance deviations

Average Wavelength (nm)	Band T	n	Wavelength Range (nm)	Transmittance T <sub>n</sub>	Percent deviation 100(1-T <sub>n</sub> /T <sub>c</sub> )	Weight	Product
430	0.114						
440	0.118						
450	0.127						
460	0.137	1	430-490	0.133	14.19	5	71.0
470	0.142						
480	0.144						
490	0.145	2	460-520	0.145	6.45	10	64.5
500	0.147						
510	0.149						
520	0.151	3	490-550	0.151	2.58	10	25.8
530	0.153						
540	0.154						
550	0.155	4	520-580	0.155	0.00	10	0.0
560	0.157						
570	0.158						
580	0.159	5	550-610	0.159	-2.58	10	25.8
590	0.160						
600	0.160						
610	0.160	6	580-640	0.160	-3.23	10	32.3
620	0.161						
630	0.161						
640	0.160	7	610-670	0.160	-3.23	10	32.3
650	0.159						
660	0.159						
670	0.158	8	640-700	0.158	-1.94	5	9.7
680	0.157						
690	0.156						
700	0.153	9	670-730	0.153	1.29	1	1.3
710	0.151						
720	0.149						
730	0.148						
					Totals	71	262.6

## NOTES:

- Spectral transmittance 520-580 nm band, T<sub>c</sub> = 0.155.
- T = Transmittance at 10 nanometers intervals.
- T<sub>n</sub> = Average transmittance of 60 nanometers band. The average transmittance T<sub>n</sub> for a given band is the average of the seven tabulated values within that band except that the first and last values are divided by 2 and the average computed by dividing the sum of the values by 6. At 520-580 nm T<sub>c</sub> = T<sub>n</sub>
- Average percentage deviation of spectral transmittance within nine spectral bands.

## MIL-PRF-32432(GL)

(Average deviation –  $262.6/71 = (3.7\%)$ )

e. This Table is based on illuminant “C”.

f. The value in the product will be considered a positive value even if the final value is a negative value.

4.4.3.4.1.5 Chromaticity test. If a configuration providing ballistic fragmentation protection and bright sunlight (sunglass) protection is offered as part of the system, the chromaticity coordinates x and y shall be calculated from spectrophotometric data. CIE Illuminant C shall be used. Table VI illustrates a sample calculation. Nonconformance to 3.6.4.1.3 shall constitute failure of this verification.

TABLE VI. Sample computation table of coordinates

Wavelength (nm)	X	y	Z	T	xT	yT	zT
380	4	-	20	0.104	0	0	2
390	19	-	89	0.240	5	0	21
400	85	2	404	0.301	26	1	122
410	329	9	1,570	0.175	90	2	432
420	1,238	37	5,949	0.174	215	6	1,035
430	2,997	122	14,628	0.110	330	13	1,609
440	3,975	262	19,938	0.093	370	24	1,854
450	3,915	443	20,638	0.092	360	41	1,899
460	3,362	694	19,299	0.100	336	69	1,930
470	2,272	1,058	14,972	0.110	250	116	1,647
480	1,112	1,618	9,461	0.122	136	197	1,154
490	363	2,358	5,274	0.132	48	311	696
500	52	3,401	2,864	0.140	7	476	401
510	89	4,833	1,520	0.142	13	686	216
520	576	6,462	712	0.142	82	918	101
530	1,523	7,934	388	0.141	215	1,119	55
540	2,785	9,149	195	0.141	393	1,290	27
550	4,282	9,832	86	0.155	664	1,524	13
560	5,880	9,841	39	0.170	1,000	1,673	7
570	7,322	9,147	20	0.167	1,223	1,528	3
580	8,417	7,992	16	0.153	1,288	1,223	2
590	8,984	6,627	10	0.142	1,276	941	1
600	8,949	5,316	7	0.136	1,217	723	1

## MIL-PRF-32432(GL)

TABLE VI. Sample computation table of coordinates - Continued

Wavelength (nm)	x	y	z	T	xT	yT	zT
Wavelength (nm)	X	y	Z	T	xT	yT	zT
610	8,325	4,176	2	0.136	1,312	568	0
620	7,070	3,153	2	0.137	969	432	0
630	5,309	2,190	0	0.137	727	300	0
640	3,693	1,443	0	0.138	510	199	0
650	2,349	886	0	0.150	352	133	0
660	1,361	504	0	0.199	256	94	0
670	708	259	0	0.270	191	70	0
680	369	134	0	0.368	136	49	0
690	171	62	0	0.475	81	29	0
700	82	29	0	0.576	47	17	0
710	39	14	0	0.620	24	9	0
720	19	6	0	0.636	12	4	0
730	8	3	0	0.643	5	2	0
740	4	2	0	0.642	3	1	0
750	2	1	0	0.632	1	1	0
760	1	1	0	0.630	1	1	0
770	1	0	0	0.600	1	0	0
				Totals	13,992	14,790	13,228

## NOTES:

- $X = \sum xT$ ,  $Y = \sum yT$ ,  $Z = \sum zT$
- Spectral transmittance,  $T_c = Y/1,000 = 14.8$  percent
- Chromaticity coordinates:  
 $x = X/(X + Y + Z) = 13,992/(13,992+14,790+13,228) = 0.3331$   
 $y = Y/(X + Y + Z) = 14,790/(13,992+14,790+13,228) = 0.3521$
- Spectral transmittance,  $T_c$ , and chromaticity coordinates,  $x$  and  $y$ , for photopic vision.
- The symbol "T" represents the transmittance, the ratio of transmitted to homogeneous radiant flux.

4.4.3.4.2 Field of view. As part of the User Evaluation, the ability of the MCEP system to provide unobscured vision with a field of view adequate for the mission will be assessed. The eyewear will be assessed both with and without the UPLC. Users that normally wear corrective lenses will be utilized to assess the adequacy of the eyewear with prescription lenses. At the end of the User Evaluation tasks, participating soldiers will rate the ability of the MCEP system design to provide an adequate field of view. An average score of "3" or higher from participating soldiers is required for successful completion of this verification. An average score of less than 3 for this test combined with an overall average score of less than 3 in all areas, or an average score of less than 2 for this test (regardless of the overall average score), shall be cause for rejection.

## MIL-PRF-32432(GL)

4.4.3.4.3 Resistance to temporary or permanent optical degradation. Complete each verification in this section.

4.4.3.4.3.1 Abrasion resistance. The haze of the coated lenses shall be determined before and after the abrasion test in accordance with ASTM D1003 procedure A Illuminate A or Illuminate C except that an aperture with an opening of 5mm in width and 15mm in height shall be inserted in the optical beam of the apparatus so that only the abraded area is measured. The abrasion test shall be performed by rubbing the front surface of the lens with a specially standardized eraser, mounted in a Summers Optical 2-1/2 lb Test Instrument Part Number 12901 (see Figure 5), and manually held approximately normal to the surface of the lens.

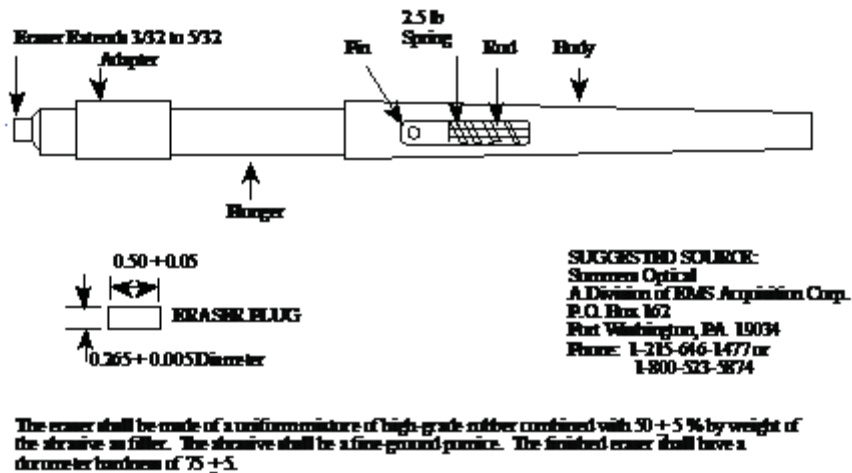

**ERASER ABRASION TESTER ASSEMBLY AND ERASER PLUG  
(DIMENSIONS IN INCHES)**

FIGURE 5. Eraser abrasion tester assembly and eraser plug

The apparatus may be held by mechanical means if demonstrated to yield results consistent with manual means. The eraser shall be made of a uniform mixture of high-grade rubber combined with 50 (+/- 5) percent (%) by weight of the abrasive as filler. The abrasive shall be fine-ground pumice. The finished eraser shall have a durometer hardness of 75 (+/-5). The eraser shall be rubbed across the surface of the coated lens from one point to another, over the same path, for 20 completed cycles with a force of 2.0 to 2.5 pounds continuously applied. A cycle is defined as one forward and backward motion. Wherever possible, rubs of about 3.0 centimeters in length are preferred. After the rubbing has been completed, the lens shall be thoroughly cleaned to remove dirt, film, fingermarks and grease marks using Dawn Dishwashing Detergent (original scent, NON-ultra) in a ratio of 8 grams of detergent per 1 liter of water by rubbing the lens with the



## MIL-PRF-32432(GL)

thumb or a non scratching non linting cleaning cloth rinsed with running water and dried with compressed air or a non scratching non linting cleaning cloth. The percent haze gain is the difference between the haze readings taken before and after the abrasion test. The lens shall be orientated such that the light source impinges the concave surface of the lens with the convex surface of the lens facing the measuring port. Nonconformance to 3.6.4.3.1 shall constitute failure of this verification

4.4.3.4.3.2 Fogging. As part of the User Evaluation, the ability of the MCEP system to provide vision unobscured by fogging will be assessed. The topical antifog treatment provided with the MCEP system shall be included as part of the test. At the end of the User Evaluation tasks, participating soldiers will rate the overall ability to complete tasks using the eyewear and topical antifog treatment. An average score of “3” or higher from participating soldiers is required for successful completion of this verification. An average score of less than 3 for this test combined with an overall average score of less than 3 in all areas, or an average score of less than 2 for this test (regardless of the overall average score), shall be cause for rejection.

4.4.3.4.4 Prismatic power. Prismatic Power of the eyewear shall be tested in accordance with ANSI Z87.1. Alternate methods may be used with Government approval. The telescope method may be used if the primary line of sight is defined by the contractor and verified by the Government, and suitable jigs are made to hold the lenses in an “as worn” position during measurement. Other methods such as autolensometers may be used with suitable jigs if calibrated to the telescopic method. Nonconformance to 3.6.4.4 shall constitute failure of this verification.

4.4.3.4.5 Optical distortion. Optical distortion of the lens shall be determined by inserting the lens with its surface normal to the line of sight into a data optics inc. “E” distortion tester, or equivalent as described in Figure 6. The area of measurement on the lens for this test shall consist of the area defined by a 50 degree field of view radius measured along the primary line of sight of the designed right and left eye locations, and starting from the center of eye rotation (13-mm behind the apex of the cornea). Lenses should be examined from the viewer’s look. Without changing the pitch and yaw of the lens with respect to the as worn position, slowly roll the lens ( $\pm$  90) degrees about the axis of the forward looking line of site so as to view the image of the straight lines in all meridians. Alternatively, the image of straight lines may be rotated ( $\pm$  90) degrees while maintaining the eyewear in the as worn position. The degree of off-parallelism shall constitute the amount of distortion, evidenced by waves or ripples. The lens shall be compared with Figure 2. Any distortion or blurs observed in the defined viewing area that fall in the unacceptable range when compared to Figure 2 shall be recorded/reported and the lens shall be inspected with a lensometer with a beam diameter in the range of 4 millimeters to 6 millimeters. The exception is if the distortion falls within 2 millimeters of the lens edge, or in an area that cannot be viewed by any line of sight (such as areas masked by the eyewear frame after final assembly). If an autolensometer is used, the refractive power shall not exceed ( $\pm$  0.125) diopters in any meridian in the area in question Nonconformance to 3.6.4.5 shall constitute failure of this verification.

MIL-PRF-32432(GL)

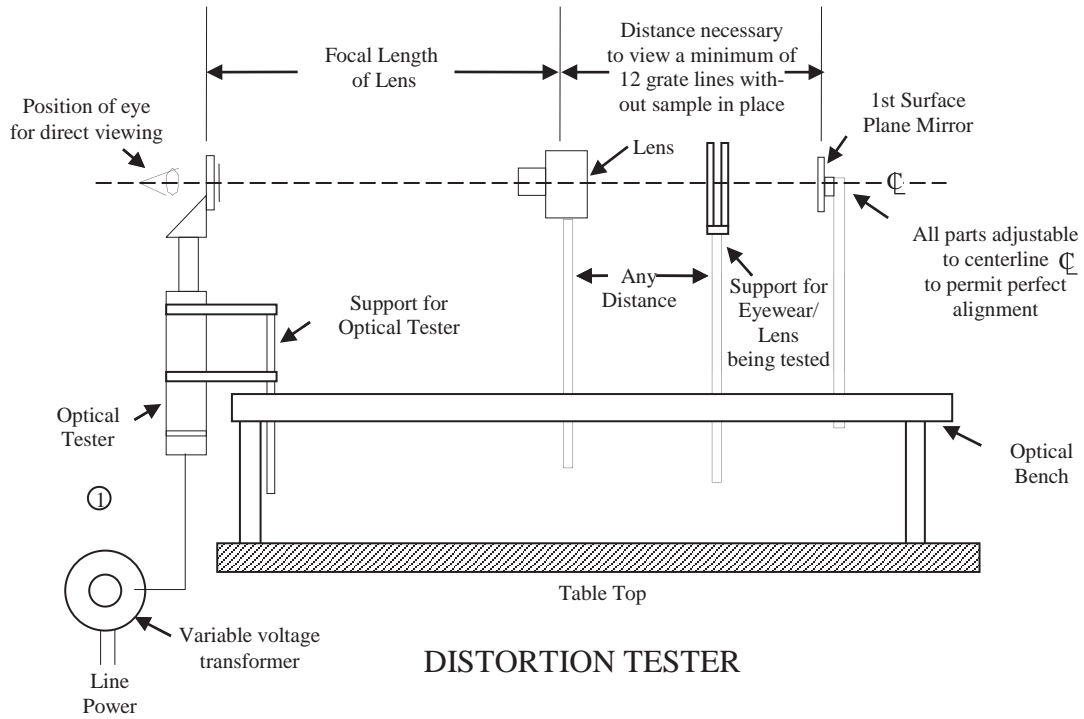

1. Model "E" Distortion Tester, or equivalent, with a 50 to 60-line grating, or equivalent (obtainable from Data Optics Inc., 115 Holmes Road, Ypsilanti, Michigan, 48198-3020, telephone 1-800-321-9026).

FIGURE 6 Distortion tester

## MIL-PRF-32432(GL)

4.4.3.4.6 Ultraviolet absorption. The spectral transmittance of the sample shall be measured with a standard spectrophotometer from 290 nanometers to 380 nanometers and the mean transmittance shall be calculated as described in ANSI Z80.3. Nonconformance to 3.6.4.6 shall constitute failure of this verification.

4.4.4 Verification of durability. Complete each verification in this section.

4.4.4.1 Carrying case protection.

4.4.4.1.1 Dirt infiltration. MCEP system shall be visually examined for a protective carrying case. The carrying case shall be examined for a means of minimizing dirt infiltration (such as secure closure around its contents), and scratching of the lenses. Nonconformance to 3.5.1.2 shall constitute failure of this verification.

4.4.4.2 Service life/shelf life. As part of the User Evaluation, the MCEP system shall be visually examined and physically manipulated to determine whether damage has occurred to the eyewear system during use. At the end of the User Evaluation tasks, participating soldiers will rate the durability of the MCEP system. An average score of “3” or higher from participating soldiers is required for successful completion of this verification. An average score of less than 3 for this test combined with an overall average score of less than 3 in all areas, or an average score of less than 2 for this test (regardless of the overall average score), shall be cause for rejection.

4.4.4.3 Repair. The eyewear system shall be disassembled to its principal component stage and switched out with replacement parts for that eyewear system without the aid of tools. Nonconformance to 3.7.3 shall constitute failure of this verification.

4.4.4.4 Environment. Complete each verification in this section.

4.4.4.4.1 Eyewear. Complete each verification in section 4.4.4.4.1

4.4.4.4.1.1 Temperature. The same MCEP eyewear system assembly shall be exposed to 160°F (+3°F) for 72 hours and -60°F (+3°F) for 72 hours. Immediately following each heat and each cold exposure samples shall also be allowed to return to ambient conditions for one hour then examined for visible signs of damage, distortion or discoloration. After visual examination all moveable parts (to include any fasteners, hinges, and any means of adjustment) shall be manually operated. Any sign of damage, distortion or discoloration beyond specification requirements or inability to operate moving parts, or the presence of breaks and cracks, shall constitute a failure of this verification. Should no damage, distortion or notable discoloration be seen then the exposed MCEP systems shall be tested for ballistic fragmentation protection in accordance with 4.4.3.3. Failure to meet the ballistic fragmentation protection requirements of 3.6.3 shall constitute failure of this verification.

4.4.4.4.1.2 Solar radiation. The MCEP eyewear system assembly shall be exposed in a weatherometer as to ASTM G 155, although with the following changes and

## MIL-PRF-32432(GL)

modifications: The weatherometer shall contain an internal, narrowband 340-nanometer or 420-nanometer self-monitoring radiometer system. Simulated solar radiant energy shall be produced via water-cooled xenon “long-arc” lamp, vertically located at the center axis of a vertical, flat, or canted 2-tier or 3-tier specimen rack. The specimen rack shall rotate at a velocity of 1.0 ( $\pm$  0.1) revolutions per minute (rpm). The xenon arc lamp shall consist of a quartz burner tube. High borosilicate type-S inner and outer optical filters shall be used. Test cycle shall consist of twenty (20) hours of full light exposure, with no water spray, followed by four (4) hours of darkness, with no water spray. Test sample(s) shall be exposed continuously for 10 complete cycles. Irradiance shall be set to 0.35 W/m<sup>2</sup>/nm or 0.75 W/m<sup>2</sup>/nm, for weatherometers employing either the 340 nanometers or 420 nanometers sensor, respectively. A rack mounted black panel thermometer/sensor shall be used to monitor black body temperature, while under test. Black panel temperature and humidity values during test shall be maintained at 63 ( $\pm$  3)<sup>o</sup>C (145 ( $\pm$  5)<sup>o</sup>F), with a relative humidity of 35 ( $\pm$  5) percent, for light-on conditions, and during the darkness phase shall be 35 ( $\pm$ 3)<sup>o</sup>C (95 ( $\pm$  5)<sup>o</sup>F), with 90 ( $\pm$ 5) percent relative humidity. At the end of the test the item shall be examined for any visible signs of damage, distortion or discoloration. Any sign of damage, distortion or discoloration beyond specification requirements shall be considered failure of this verification. Should no damage, distortion or notable discoloration be seen then the exposed MCEP systems shall be tested for ballistic fragmentation protection in accordance with 4.4.3.3. Failure to meet the ballistic fragmentation protection requirements of 3.6.3 shall constitute failure of this verification.

4.4.4.4.1.3 Humidity. The eyewear assemblies shall be placed in a chamber that is capable of cycling the humidity and temperature according to Table VII. The samples shall be exposed to 10 complete cycles. Immediately upon completion of the humidity test and removal from the humidity chamber, the samples shall be dried with a non scratching non linting cleaning cloth or compressed air and then subjected to the adhesion test (4.4.4.4.1.4). Following the adhesion test, the product shall be visually assessed for damage, distortion or discoloration on the opposite (left or right) ocular. Any visible sign of damage, distortion or discoloration beyond specification requirements shall constitute failure of this verification. Should no sign of damage, distortion or notable discoloration on the sample be seen then the exposed lenses shall be tested for ballistic fragmentation protection in accordance with 4.4.3.3. Failure to meet the ballistic fragmentation protection requirements of 3.6.3 shall constitute failure of this verification.

## MIL-PRF-32432(GL)

TABLE VII. Relative humidity and temperature versus time

Start Time	Temperature °F	Temperature °C	Relative Humidity RH Percent (%)
0000	95	35	63
0100	95	35	67
0200	94	34	72
0300	94	34	75
0400	93	34	77
0500	92	33	79
0600	95	33	80
0700	97	36	70
0800	104	40	54
0900	111	44	42
1000	124	51	31
1100	135	57	24
1200	144	62	17
1300	151	66	16
1400	156	69	15
1500	160	71	14
1600	156	69	16
1700	151	66	18
1800	145	63	21
1900	136	58	29
2000	122	50	41
2100	105	41	53
2200	103	39	58
2300	99	37	62

4.4.4.4.1.4 Adhesion. A test tape, with an adhesion rating of 40 ounces per 2.5 centimeters of width, shall be firmly applied to the front surface of the lens and the back surface of the lens. The minimum area covered shall be 13 square centimeters. To ensure good contact, rub the area firmly with an eraser. Within 90 ( $\pm$  30) seconds of application, the tape shall be rapidly (not jerked) removed by pulling it back upon itself at an angle as close to 180 degrees as possible. Inspect the area to which the tape was applied for removal of coating. Removal or loosening of the coating on the front surface or back surface of the lens shall be cause for failure of this verification and cause for rejection of the lot. ASTM D 3359 may be used as a reference.

4.4.4.4.1.5 Wind/dust. As part of the User Evaluation, the ability of the Class 2 and Class 3 MCEP system to provide protection to the eyes from wind and dust. At the end of the User Evaluation tasks, participating soldiers will rate the ability of the Class 2 and Class 3 MCEP system design to provide protection to the eyes from wind and dust. An average score of “3” or higher from participating soldiers is required for successful completion of this verification. An average score of less than 3 for this test combined

## MIL-PRF-32432(GL)

with an overall average score of less than 3 in all areas, or an average score of less than 2 for this test (regardless of the overall average score), shall be cause for rejection.

4.4.4.4.1.6 Salt water. The items shall be tested for corrosion resistance in accordance with ANSI Z87.1 except that the eyewear shall be exposed fully assembled. Once exposure is complete and the eyewear is dry, the assembly shall be checked for functional impairment and for visible signs of degradation of the frame affecting the integrity of the item. Inability or difficulty in articulation of parts or any visible sign of degradation of the frame shall constitute failure of this verification. Nonconformance to 3.7.4.1.6 shall constitute failure of this verification.

4.4.4.4.2. Carrying case. As part of the User Evaluation, the ability of the MCEP system Carrying Case to be operable and resistant to breaks and cracks, discoloration, corrosion, and rust during operation, shipping, and storage will be assessed. At the end of the User Evaluation tasks, participating soldiers will rate the Carrying Case on the above. An average score of “3” or higher from participating soldiers is required for successful completion of this verification. An average score of less than 3 for this test combined with an overall average score of less than 3 in all areas, or an average score of less than 2 for this test (regardless of the overall average score), shall be cause for rejection.

#### 4.4.5 Human factors verification.

4.4.5.1 Fit/adjustment. Complete each verification in this section.

4.4.5.1.1 Sizing/fit. As part of the User Evaluation, the ability of the MCEP system to accommodate (i.e., fit, adjust, number of sizes, and/or successful use) U.S. Army target audience soldiers with 5th percentile female through 95th percentile male design critical dimensions, while wearing appropriate clothing and individual equipment will be assessed. Verification of fit with the helmets, weapons, and equipment shall be determined via the verifications of 4.4.2.3.1 through 4.4.2.3.6. Test participants requiring prescription correction shall also assess the interface of the eyewear with the UPLC for fit. At the end of the User Evaluation tasks, participating soldiers will rate the Sizing and Fit of the MCEP system. An average score of “3” or higher from participating soldiers is required for successful completion of this verification. An average score of less than 3 for this test combined with an overall average score of less than 3 in all areas, or an average score of less than 2 for this test (regardless of the overall average score), shall be cause for rejection. Any discomfort exhibited at any point during the above shall be noted and applied to paragraph 4.4.5.2.

4.4.5.1.2 Pantoscopic tilts and faceform angles. The eyewear (without prescription lenses installed) shall be mounted in the as worn position on an appropriately sized EN headform for the eyewear under test. The pantoscopic tilt shall be determined by measuring the angle formed between the intersection of the following two lines, as viewed from the side of the headform (i.e., 90 degrees from the line of sight of the headform):

## MIL-PRF-32432(GL)

1. a vertical line tangent to the upper rim of the prescription lens carrier at a point 32 mm from the vertical centerline of the carrier.
2. a line segment tangent to the upper rim of the prescription lens carrier at a point 32 mm from the vertical centerline, and tangent to the lower rim of the prescription lens carrier at a point 32 mm from the vertical centerline of the carrier.

The angle (in degrees) may be measured physically (such as with a coordinate-measuring machine, or pendulum/protractor) or , photographically (with a drop line as a visual aide for measuring the angle formed in the photographic image), by measuring the angular reflection of a laser beam off a mirrored lens installed into the carrier, or other suitable method. The faceform angle is considered positive if the lower rim of the prescription lens carrier falls between the headform and the vertical line described in 1 above. The faceform angle is considered negative if the lower rim of the carrier falls outside this line away from the headform.

The eyewear assembly shall also be visually inspected for physical interference with the natural faceform angle of the UPLC (without prescription lenses installed).

Visible changes to the faceform angle of the UPLC when installed in the eyewear, negative pantoscopic tilt, or inability to conform to the pantoscopic tilt requirements of 3.8.1.2 shall constitute failure of this verification.

4.4.5.1.3 Adjustment. As part of the User Evaluation, the MCEP system shall be visually examined and physically manipulated to determine whether a means of adjustment for proper fit/comfort is present and to determine its effectiveness. At the end of the User Evaluation tasks, participating soldiers will rate the means of adjustment for proper fit/comfort of the MCEP system. An average score of “3” or higher from participating soldiers is required for successful completion of this verification. An average score of less than 3 for this test combined with an overall average score of less than 3 in all areas, or an average score of less than 2 for this test (regardless of the overall average score), shall be cause for rejection.

4.4.5.2 Comfort. As part of the User Evaluation, the Comfort of the MCEP system will be assessed. Any discomfort exhibited during performance of verification paragraph 4.4.5.1.1 or 4.4.2.3.1 through 4.4.2.3.6 shall be applied here. The MCEP system shall also be examined (by sight and feel) for any sharp or rough edges. Any sharp or rough edge that could result in discomfort or abrasion to the users face or prevalent hot spots shall be considered failure of this verification. At the end of the User Evaluation tasks, participating soldiers will rate the comfort of the MCEP system. An average score of “3” or higher from participating soldiers is required for successful completion of this verification. An average score of less than 3 for this test combined with an overall average score of less than 3 in all areas, or an average score of less than 2 for this test (regardless of the overall average score), shall be cause for rejection.

4.4.5.3 Donning/doffing. As part of the User Evaluation, the ability of the MCEP system to be donned/doffed will be assessed. Throughout the evaluation, soldiers will be retrieving and donning/doffing the MCEP system while wearing required helmets and

## MIL-PRF-32432(GL)

equipment and while performing assigned tasks. At the end of the User Evaluation tasks, participating soldiers will rate the ability of the MCEP system to be donned/doffed. An average score of “3” or higher from participating soldiers is required for successful completion of this verification. An average score of less than 3 for this test combined with an overall average score of less than 3 in all areas, or an average score of less than 2 for this test (regardless of the overall average score), shall be cause for rejection.

4.4.5.4. Use. As part of the User Evaluation, the users will perform the following:

- a. Stow/remove MCEP system to/from carrier.
- b. Adjust Class 1 and Class 1a MCEP system to fit on the face in the as worn configuration under the helmet (LWH, ECH, ACH; CVC(As applicable))
- c. Adjust Class 2, Class 2a, Class 3 and Class 3a MCEP system to fit over the helmet (CVC; LWH, ECH, ACH).
- d. Adjust Class 2, Class 2a, Class 3 and Class 3a MCEP system to fit on the face in the as worn configuration under the helmet (CVC; LWH, ACH, ECH).
- e. Install/remove lenses
- f. Manipulate movable parts
- g. Perform operator level Preventative Maintenance Checks and Services (PMCS)
- h. Install/remove UPLC (Class 1a, 2a and 3a only).

At the end of the User Evaluation tasks, participating users will rate the ability to use the MCEP system. An average score of “3” or higher from participating users is required for successful completion of this verification. An average score of less than 3 for this test combined with an overall average score of less than 3 in all areas, or an average score of less than 2 for this test (regardless of the overall average score), shall be cause for rejection.

4.4.5.5 User survivability. As part of the User Evaluation, the impact of the MCEP system upon user survivability will be assessed. Users will assess their ability to detect the MCEP system by reflected light. At the end of the User Evaluation tasks, participating soldiers will rate the User Survivability aspects of the MCEP system. An average score of “3” or higher from participating soldiers is required for successful completion of this verification. An average score of less than 3 for this test combined with an overall average score of less than 3 in all areas, or an average score of less than 2 for this test (regardless of the overall average score), shall be cause for rejection.

4.4.6 Safety/health hazards. Safety will be verified by verifying that MCEP system can be used together with other protective equipment, by verifying that MCEP system provides the protective capabilities for which it was designed, and by verifying that MCEP system complies with the American National Standard practice for occupational and educational eye and face protection. Therefore, much of the Safety requirement will be considered met by satisfaction of the following verification paragraphs: 4.4.2.3.1, through 4.4.2.3.7, 4.4.3.3, 4.4.3.4, 4.4.5.1.1, 4.4.8 and 4.4.9. As part of the User Evaluation, the impact of the MCEP system upon Safety/Health will be assessed. Users



## MIL-PRF-32432(GL)

will assess whether prolonged wearing of the MCEP system causes headaches, dizziness, blurred vision, or undue eyestrain. At the end of the User Evaluation tasks, participating soldiers will rate the Safety/Health aspects of the MCEP system. An average score of “3” or higher from participating soldiers is required for successful completion of this verification. An average score of less than 3 for this test combined with an overall average score of less than 3 in all areas, or an average score of less than 2 for this test (regardless of the overall average score), shall be cause for rejection. Additionally, end items shall be visually inspected to ensure MCEP is free of sharp/rough edges and constructed from materials that are easy to keep clean/sanitary, particularly in areas that contact the skin.

4.4.7 Identification and marking. Identification and Marking of the eyewear shall be visually inspected to determine that the information identified in section 3.10 is on the eyewear, and is accessible without destroying the item, does not degrade the performance of the eyewear and is not in the users field of view. Nonconformance to 3.10 shall constitute failure of this verification.

4.4.8 Compliance with ANSI Z87.1. The eyewear shall be evaluated in accordance/compliance with ANSI Z87.1-2010 except a) where otherwise noted in this specification and b) a minimum of three samples shall be used for each test if less than three samples are specified. Test fixtures, velocity measurements, temperature/humidity requirements shall all be performed and maintained in accordance with ANSI Z87.1-2010. ANSI Z87.1 optical tests shall be tested on the appropriate sized EN head form for the product under test, or as specified in ANSI Z87.1 and shall be conducted in the critical optical area (defined by a circle having a 20 millimeters radius centered on the horizontal centerline and 32 millimeters from the vertical centerline), unless otherwise specified in ANSI. The size medium EN head form shall be used for one-size-fits-all products. Eyewear shall be tested in all configurations (to include the use of multiple nosepieces to accommodate both prescription and non-prescription wearers and with/without optional components that alter standoff distance from the face (such as removable face foam). Nonconformance to 3.11 and all applicable requirements of ANSI Z87.1 shall constitute failure of this verification.

4.4.9 Flammability. The eyewear systems shall be tested for flammability in accordance with 4.4.9.1 and 4.4.9.2.

4.4.9.1 ANSI flammability. The MCEP system eyewear shall be tested in accordance with both ANSI Z87.1-2003 and ANSI Z87.1-2010. Nonconformance to 3.12.1 and all applicable requirements of ANSI Z87.1 shall constitute failure of this verification.

4.4.9.2 Textile flammability. Five samples of each textile component of the Class 2 and Class 3 eyewear assemblies shall be tested in accordance with ASTM D 6413 with the following exceptions: sample length may be 20-25 cm in length and the standard test fixtures may be modified to better accommodate retention strap samples (such as through the use of narrow clips at periodic intervals along the edge of the sample holder to prevent the sample from moving or curling away from the flame; edges shall not be held

## MIL-PRF-32432(GL)

along the entire periphery to avoid impeding any burning that may occur and documented in the test report; the test fixture shall not be such that it prevents the strap from otherwise burning; retention strap samples will only be tested in the lengthwise direction due to narrowness of the strap and the nature of the test; afterflame and char length shall be measured and recorded as part of the results; afterglow will be noted and recorded as an observation. Each test specimen shall be suspended using fixtures and/or clamping that will ensure the specimen is held firmly in place around its periphery in a vertical position and the flame applied to the center portion of the strap only. Char length for goggle straps shall be determined by measuring the amount of material visibly charred/consumed after testing, which may appear as an area of reduced elasticity (based on initial and post-test sample lengths), rather than applying the specified force to the sample. Elasticity of the sample shall be checked before the test to determine normal elasticity of the material. Nonconformance to 3.12.2 shall constitute failure of this verification.

4.4.10 Toxicity test. Unless otherwise specified, (see 6.2), an acute dermal irritation study and a skin sensitization study shall be conducted on laboratory animals. When the results of these studies indicate the eyewear is not a sensitizer or irritant, a Repeat Insult Patch Test shall be performed in accordance with the Modified Draize Procedure. (see 2.3). If the toxicity requirement (see 3.9.3) can be demonstrated with historical use data, toxicity testing may not be required (see 6.2).

4.4.11 Workmanship. End items shall be visually inspected and manually operated to ensure the product is free from all defects which would affect proper functioning in service. Lens defects are addressed in 4.3. Parts (zippers, snaps, hook and pile, glides, adjustable features, etc.) shall be easy to manipulate and provide a secure hold as evidenced by manual manipulation. Removable components shall be easily removed and reinstalled, and interfaces shall be secure (to include UPLC interface for Class 1a, Class 2a, and Class 3a). Kits shall be examined to ensure all components are present, and no pieces/parts missing. Textile components shall be examined to ensure there are no rips/tears/holes. Stitching shall be inspected to ensure it is complete, durable and secure (i.e., no loose/broken/missing stitching; stitching does not easily become undone). Components shall be inspected to ensure they are free of abrasive edges.

## 5. PACKAGING

5.1 Packaging. For acquisition purposes, the packaging requirements shall be as specified in the contract or order (see 6.2). When actual packaging of material is to be performed by DoD or in-house contractor personnel, these personnel need to contact the responsible packaging activity to ascertain requisite packaging requirements. Packaging requirements are maintained by the Inventory Control Point's packaging activities within the Military Department or Defense Agency, or within the military service's system commands. Packaging data retrieval is available from the managing Military Department's or Defense Agency's automated packaging files, CD-ROM products, or by contacting the responsible packaging activity.

## MIL-PRF-32432(GL)

## 6. NOTES

(This section contains information of a general or explanatory nature that may be helpful, but is not mandatory.)

6.1 Intended use. MCEP system is intended for use by military personnel for eye protection against ballistic fragmentation (primary function), electromagnetic radiation, and sand/wind/dust.

6.1.1 Qualifying activity. Product Manager Soldier Protective Equipment (PM-SPE) is designated by the preparing activity as the qualifying activity to administer the MCEP QPL program and maintain this specification.

6.2 Acquisition requirements. Acquisition documents should specify the following:

- a. Title, number, and date of this specification.
- b. Classes of MCEP System (see 1.2)
- c. When first article is required (see 3.3 and 4.2)
- d. When toxicity testing is required (see 3.9.3 and 4.4.10)
- e. When bar coding (if applicable) is required (see 3.10.2)
- f. Conformance inspection Acceptance Quality Limit (AQL) (see 4.1.2)
- g. Inspection conditions (see 4.1.2.1)
- h. Lot size and sample size and acceptance criteria (see 4.1.2.3)
- i. Packaging (see 5.1)

6.3 Qualification. With respect to products requiring qualification, awards will be made only for products which are, at the time of award of contract, qualified for inclusion in the MCEP QPL whether or not such products have actually been so listed by that date. The attention of the contractors is called to these requirements, and manufacturers are urged to arrange to have the products that they propose to offer to the Federal Government tested for qualification in order that they may be eligible to be awarded contracts or orders for the products covered by this specification. Information pertaining to qualification of products may be obtained from Product Manager - Soldier Protective Equipment, ATTN: SFAE-SDR-SPE, 10170 Beach Road, Building 328T, Fort Belvoir, VA 22060-5800.

6.3.1 First article. When a first article is required, it will be inspected and approved under the appropriate provisions of FAR 52.209. The first article should be a preproduction sample consisting of one completed assembly. The contracting officer should include specific instructions in all acquisition instruments regarding arrangements for selection, inspection, and approval of the first article.

6.4 Qualified products list manufacturing facility audits. All audits will be conducted by PEO-Soldier quality assurance personnel. The audit will use ISO 9001 2008 as the baseline and guide for the conduct of the audit.

## MIL-PRF-32432(GL)

NOTE: There is no requirement for vendor's to be ISO certified or to be compliant with ISO 9001 2008. However, they must demonstrate that they have an effective Quality Assurance System that delivers high quality product, meeting all the government requirements.

The PEO-Soldier audit will issue both observations and non-conformances that are encountered during the audit. These will be contained in a Final Report which will be provided by the auditors to the vendor as soon as possible after the audit. Observations which contain opportunities for improvement, do not require immediate vendor corrective actions, but should be routinely corrected prior to the next annual audit. Observations may also contain areas of excellence and commendation for employees or Sections/Teams which are doing outstanding work. These observations do not need to be addressed at all. All Non-conformances will be issued on a form standardized by PEO-Soldier and will require signatures of the vendor's responsible manager and the Vendor's Quality assurance manager. This form constitutes a contract for corrective actions which must be completed within the specified timeframe. Failure to complete non-conformance corrective actions will constitute an immediate major non-conformance during the next annual inspection and consideration for removal from the QPL.

6.4.1. Initial assessment audit. Vendors who have passed physical property testing and user evaluation testing will have their Quality Management System (QMS) and production facilities audited by PEO-Soldier prior to addition of the item/s to the MCEP QPL. The QMS will be shown to be acceptable to PEO-Soldier or the item/s will not be added to the QPL until the QMS has been shown to be an acceptable level. Acceptable level is defined as no major non-conformances will be found during the audit.

6.4.2 Prime vendor audits. Vendors who have products on the MCEP Qualified Products List (QPL) will have their Quality Management System (QMS) and production facilities audited at a minimum once a year.

6.4.3 Subcontractors audits. All Subcontractors of Vendors with products on the QPL will be audited once a year as time and situations dictate. The audits will be conducted in the same manner as the vendor audits. Special emphasis may be placed on areas dependent upon the products and services provided by the subcontractors and current programmatic issues.

6.5 Safety definitions Safety definitions for Table I are as follows:

- Catastrophic (Category I): Death or system loss
- Critical (Category II): Severe injury, severe occupational illness, or major system damage
- Marginal (Category III): Minor injury, minor occupational illness, or minor system damage
- Negligible (Category IV): Less than minor injury, occupational illness, or minor system damage
- Frequent (Level A): Likely to occur frequently

MIL-PRF-32432(GL)

Probable (Level B): Will occur several times in the life of an item

Occasional (Level C): Likely to occur some time in the life of an item

Remote (Level D): Unlikely, but possible to occur in the life of an item

Improbable (Level E): So unlikely, it can be assumed occurrence may not be experienced.

6.6 Standard sample. For access to samples, address the Contracting Activity issuing the invitation for Bids or Request for Proposal. Federal-STD-595C

6.7 Subject term (key word) listing

Fragmentation  
Glasses  
Ballistic  
Sun

6.8 Source of supply

Scratch and Dig Paddle: Edmund Optics Part number NT53-197.

Chemicals:

Fire Resistant Hydraulic Fluid (MIL-H-46170) - Royco #770

Hydraulic Fluid Petroleum Base (MIL-PRF-6083) - Royco #783

Cleaning Cloth: 3M Lens Cleaning Cloth 9021

Insect repellent-controlled release 30% concentration DEET – 3M Ultrathon

Insect Repellent Lotion (water based), or equivalent

Custodians

Army - GL  
DLA-IS

PREPARING ACTIVITY:

Army - GL

(Project Number 4240-2012-009)

NOTE: The activities listed above were interested in this document as of the date of this document. Since organizations and responsibilities can change, you should verify the currency of the information above using ASSIST Online database at <https://assist.dla.mil/>.